Metrological regulation for load cells

Part 4: Annexes

Réglementation métrologique des cellules de pesée

Annexes



Contents

Foreword	4
Annex A Definitions from other applicable international publications.....	5
Annex B OIML certificate for load cells — Content of the certificate.....	8
Annex C OIML certificate for load cells.....	10
Annex D Selection of load cell(s) for testing — a practical example.....	14
Annex E Load transmission to the load cell.....	19
Annex F Bibliography.....	23

Foreword

The International Organisation of Legal Metrology (OIML) is a worldwide, intergovernmental organisation whose primary aim is to harmonise the regulations and metrological controls applied by the national metrological services, or related organisations, of its Member States. The main categories of OIML publications are:

- **International Recommendations (OIML R)**, which are model regulations that establish the metrological characteristics required of certain measuring instruments and which specify methods and equipment for checking their conformity. OIML Member States shall implement these Recommendations to the greatest possible extent;
- **International Documents (OIML D)**, which are informative in nature and which are intended to harmonise and improve work in the field of legal metrology;
- **International Guides (OIML G)**, which are also informative in nature and which are intended to give guidelines for the application of certain requirements to legal metrology;
- **International Basic Publications (OIML B)**, which define the operating rules of the various OIML structures and systems; and

OIML Draft Recommendations, Documents and Guides are developed by Project Groups linked to Technical Committees or Subcommittees which comprise representatives from OIML Member States. Certain international and regional institutions also participate on a consultation basis. Cooperative agreements have been established between the OIML and certain institutions, such as ISO and the IEC, with the objective of avoiding contradictory requirements. Consequently, manufacturers and users of measuring instruments, test laboratories, etc. may simultaneously apply OIML publications and those of other institutions.

International Recommendations, Documents, Guides and Basic Publications are published in English (E) and translated into French (F) and are subject to periodic revision.

Additionally, the OIML publishes or participates in the publication of **Vocabularies (OIML V)** and periodically commissions legal metrology experts to write **Expert Reports (OIML E)**. Expert Reports are intended to provide information and advice, and are written solely from the viewpoint of their author, without the involvement of a Technical Committee or Subcommittee, nor that of the CIML. Thus, they do not necessarily represent the views of the OIML.

This publication — Annexes to OIML R 60:2021 — is an updated edition (developed by the OIML Certification System Management Committee) of the Annexes to R 60:2017 (developed by Project Group 1 of OIML Technical Committee TC 9 *Instruments for measuring mass and density*). This updated edition consolidates the Amendment (2019-12-23) to R 60:2017, and includes other editorial and minor technical changes. It was approved for final publication by the International Committee of Legal Metrology at its 56th meeting in October 2021 and was sanctioned by the 16th International Conference on Legal Metrology in 2021. It supersedes the previous edition of R 60 dated 2017.

OIML Publications may be downloaded from the OIML web site in the form of PDF files. Additional information on OIML Publications may be obtained from the Organisation's headquarters:

Bureau International de Métrologie Légale
11, rue Turgot — 75009 Paris — France
Telephone: 33 (0)1 48 78 12 82
Fax: 33 (0)1 42 82 17 27
E-mail: biml@oiml.org
Internet: www.oiml.org

Annex A (Mandatory)

Definitions from other applicable international publications

A.1 Terms and definitions

A.1.1

electronic measuring instrument (OIML D 11, 3.1)

instrument intended to measure an electrical or non-electrical quantity using electronic means and/or equipped with electronic devices

A.1.2

module (OIML D11, 3.2)

device performing a specific function or functions and (usually) manufactured and constructed such that it can be separately evaluated according to prescribed metrological and technical performance requirements

A.1.3

device (OIML D 11, 3.3)

identifiable instrument or part of an instrument or of a family of instruments that performs a specific function or functions

A.1.4

checking facility (OIML D11, 3.19)

facility incorporated in a measuring instrument which enables significant faults to be detected and acted upon

A.1.5

automatic checking facility (OIML D 11, 3.19.1)

checking facility that operates without the intervention of an operator

A.1.6

permanent automatic checking facility (type P) (OIML D 11, 3.19.1.1)

automatic checking facility that operates at each measurement cycle

A.1.7

intermittent automatic checking facility (type I) (OIML D 11, 3.19.1.2)

automatic checking facility that operates at certain time intervals or per fixed number of measurement cycles

A.1.8

non-automatic checking facility (type N) (OIML D 11, 3.19.2)

checking facility that requires the intervention of an operator

**A.1.9
durability protection facility (OIML D 11, 3.20)**

facility incorporated in a measuring instrument that enables significant durability errors to be detected and acted upon

**A.1.10
test (OIML D 11, 3.21)**

series of operations intended to verify the compliance of the equipment under test (EUT) with specified requirements

**A.1.11
test procedure (OIML D 11, 3.21.1)**

detailed description of the test operations

**A.1.12
performance test (OIML D 11, 3.21.4)**

test intended to verify whether the EUT is able to accomplish its intended functions

**A.1.13
mains power (OIML D 11, 3.22)**

primary external source of electrical power for an instrument, including all sub-assemblies. (Examples: public or local power grid (AC or DC) or external generator)

**A.1.14
power converter (power supply device) (OIML D 11, 3.23)**

sub-assembly converting the voltage from the mains power to a voltage suitable for other sub-assemblies

**A.1.15
auxiliary battery (OIML D 11, 3.25)**

battery that is

- mounted in, or connected to, an instrument that can be powered by the mains power as well, and
- capable of supplying power to the complete instrument for a reasonable period of time

**A.1.16
back-up battery (OIML D 11, 3.26)**

battery that is intended to maintain power supply for specific functions of an instrument in the absence of the primary power supply that includes both mains power & auxiliary battery

Example To preserve stored data

A.2 Definitions from OIML R 76 [1]

**A.2.1
weighing module (OIML R 76-1, T.2.2.7)**

part of the weighing instrument that comprises all mechanical and electronic devices (i.e. load receptor, load-transmitting device, load cell, and analogue data processing device or digital data processing

device) but not having the means to display the weighing result. It may optionally have devices for further processing (digital) data and operating the instrument

Annex B
(Mandatory)

OIML certificate for load cells — Content of the certificate

The OIML certificate template that can be downloaded from the “Documentation” section of the OIML Certification System (OIML-CS) part of the OIML website shall be supplemented with the following additional information:

<i>Model designation</i>				
Maximum capacity, E_{\max}				
Accuracy class				
Maximum number of load cell				
verification intervals, n_{LC}				
Minimum load cell verification				
interval, v_{\min}				
Apportioning factor, p_{LC}				

Additional characteristics and identification, as applicable according to R 60-1, 3.4.2 and 5.1.5, may be included in the certificate or on additional pages if necessary, in the format below:

<i>Model designation</i>				
(Additional characteristics, per R 60-1, 3.4.2 and 5.1.5)				

Special conditions:

B.1 Contents of any additional pages to the certificate (Informative)

Name and type of the load cell:

B.2 Technical data

The essential technical data for OIML certificates are listed on the certificate (at the request of the manufacturer). Alternatively, in the case of limited space on the certificate, the following information may be provided on additional pages to the certificate:

Table B.1 — Technical data

Model designation	Designation	Example		Units
Classification		C4		
Additional markings		-		
Maximum number of load cell verification intervals	n_{LC}	4 000		
Maximum capacity	E_{max}	30 000		kg
Minimum dead load, relative	E_{min}/E_{max}	0		%
Relative v_{min} (ratio to minimum load cell verification interval)	$Y = (E_{max} - E_{min}) / (v_{min})$	24 000		
Relative DR (ratio to minimum dead load output return)	$Z = (E_{max} - E_{min}) / (2 \times DR)$	7 500		
Rated output ^a		2.5		mVV ^{-1a}
Maximum excitation voltage		30		V
Input impedance (for strain gauge load cells)	R_{LC}	4 000		Ω
Temperature rating		— 10/+40		°C
Safe overload, relative	E_{lim}/E_{max}	150		%
Cable length		3		m
Additional characteristics per R 60-1, 3.4.2 and 5.1.5 ^b		-		
^a For load cells with digital output this refers to the number of counts for E_{max} . ^b For load cells with digital output this is not required.				

Annex C (Informative) OIML certificate for load cells

This Annex is provided as an example of supplemental information that may be included in the OIML certificate and is intended to complement the information found in Annex B.

C.1 Certificate history

Certificate version	Date	Essential changes
Rev. 0	DD MM YYYY	Certificate first issued

C.2 Technical data

The metrological characteristics of the load cells type xxx are listed in Table C.1. Further technical data are listed in the data sheet of the manufacturer (see the section “6 Data sheet and dimensions” in this Annex).

Table C.1 — Essential data

Accuracy class		C
Maximum number of load cell intervals n_{LC}		3 000
Rated output	mVV ⁻¹	2
Maximum capacity E_{max}	kg	150 / 200 / 250 / 300 / 500 / 750
Minimum load cell verification interval $v_{min} = (E_{max} - E_{min}) / Y$	kg	$E_{max} / 15\ 000$
Minimum dead load output return $DR = 1/2 (E_{max} - E_{min}) / Z$	kg	$1/2 (E_{max} - E_{min}) / 5\ 000$

Dead load: xxx % · E_{max} ; Safe overload: xxx % · E_{max} ; Input impedance: xxx Ω

C.3 Tests

The determination of the measurement error, the stability of the dead load output, repeatability and creep in the temperature range of $-10\ ^\circ\text{C}$ to $+40\ ^\circ\text{C}$ as well as the tests of barometric pressure effects and the determination of the effects of damp heat steady state have been performed according to OIML R 60 as shown in Table C.1 on the load cell denominated in the test report with the reference No. xxx, dated xxx.

Table C.2 — Tests performed

Test	R 60	Tested samples	Result
Temperature test and repeatability at ($20/40/-10/20\ ^\circ\text{C}$)	R 60-1, 5.3.2; 5.4; R 60-2, 2.10.1	150 kg	+

Table C.2 (continued)

Test	R 60	Tested samples	Result
Temp. effect on minimum dead load output at (20/40/ – 10/20 °C)	R 60-1, 5.6.1.3; R 60-2, 2.10.1.16	150 kg	+
Creep test at (20/40/ – 10/20 °C)	R 60-1, 5.5.1; R 60-2, 2.10.2	150 kg	+
Minimum dead load output return at (20/40/ – 10/20 °C)	R 60-1, 5.5.2; R 60-2, 2.10.3	150 kg	+
Barometric pressure effects at ambient temperature	R 60-1, 5.6.2; R 60-2, 2.10.4	150 kg	+
Damp heat test, static, marked SH	R 60-1, 5.6.3.2; R 60-2, 2.10.6	150 kg	+

C.4 Description of the load cell

Example:

The load cells (LC) of the series xxx are double bending beam load cells. They are made of aluminium, and the strain gauge application is hermetically sealed. Further essential characteristics are given in the data sheet (see the section “6 Data sheet and dimensions” in this Annex).

[Include a picture/diagram of the load cell]

Figure 1 — Load cell type xxx

The complete type designation is indicated as follows in the example on the name plate:

[Include a picture/diagram of the name plate]

Figure 2 — Name plate

C.5 Documentation

Example:

- Test Report No. xxx; C3; Y = xxx; Z = xxx; E_{\max} = xxx kg; SN: xxx
- Datasheet No. Xxx
- Technical Drawing No. Xxx

C.6 Further information

The manufacturing process, material and sealing (i.e., environmental protection) of the produced load cells shall be in accordance with the tested patterns; essential changes shall be identified and communicated to the issuing authority and are only allowed with the permission of the issuing authority based on the impact of those changes on the certification process.

Sufficient information shall be included to describe the patent design.

The typical errors related to linearity, hysteresis and temperature coefficient as indicated in the data sheet point out possible single errors of a pattern; however, the overall error of each pattern is determined by the maximum permissible error according OIML R 60-1, 5.3.2.

The technical data, the dimensions of the load cell and the principle of load transmission are given in section 6 of this Annex, “Data sheet and dimensions”, and shall be complied with.

C.7 Data sheet and dimensions

Specifications of the load cell family

Accuracy class according to OIML R 60			C
Rated output		mVV ⁻¹	2,0 ± 0,2
Maximum capacity	E_{\max}	kg	150 / 200 / 250 / 300 / 500 / 750
Max. number of load cell intervals	n_{LC}		3 000
Min. load cell verification interval	v_{\min}	kg	$E_{\max} / 15\ 000$
Minimum dead load output return (MDLOR)	DR	kg	$1/2 \cdot E_{\max} / 5\ 000$
Minimum dead load		$\% \cdot E_{\max}$	0
Safe load limit		$\% \cdot E_{\max}$	150
Ultimate load		$\% \cdot E_{\max}$	300
Excitation voltage, recommended	U_{EXE}	V	10-12 DC
Excitation voltage, maximum		V	15 DC
Input resistance	R_{LC}	Ω	404 ± 10
Output resistance	R_{out}	Ω	350 ± 3
Insulation resistance	RISO	M Ω	≈ 2 000
Compensated temperature range	T	°C	- 10 ... + 40
Load cell material			Aluminium
Cable length	L	m	2
Coating			Silicone rubber

C.8 Wiring

The load cell is provided with a shielded 4- or 6-wire cable. The cable length is indicated in the accompanying document. The shield will be connected or not connected to the load cell according to the customer's preference.

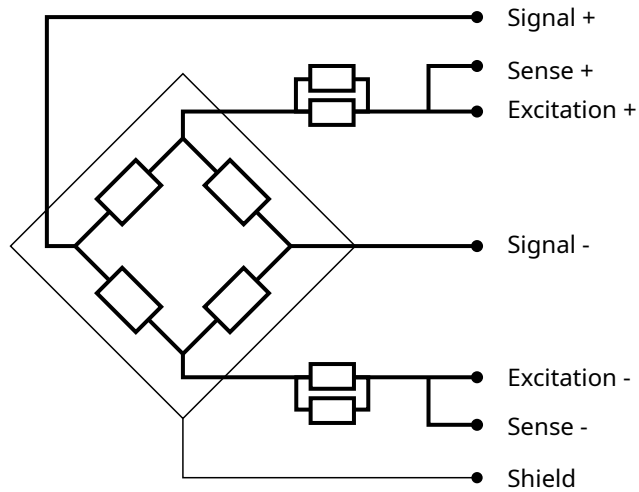

C.9 Connections

Connections	4-wire	6-wire
Excitation +	red	red
Excitation -	black	black
Signal +	green	green
Signal -	white	white
Sense +	-	blue
Sense -	-	yellow
Shield	purple	purple
Cable length	2 m	

C.10 Dimensions

[Include a picture/diagram of the load cell dimensions]

Annex D (Informative)

Selection of load cell(s) for testing — a practical example

D.1 This Annex describes a practical example showing the complete procedure for the selection of test samples out of a load cell family.

D.2 Assume a family consisting of three groups of load cells, differing in class, maximum number of load cell verification intervals, n_{LC} , and maximum capacities, E_{max} . The capacities, E_{max} , overlap between the groups according to the following example:

- Group 1 Class C, $n_{LC} = 6\ 000$, $Y = 18\ 000$, $Z = 6\ 000$
 E_{max} : 50 kg, 100 kg, 300 kg and 500 kg
- Group 2 Class C, $n_{LC} = 3\ 000$, $Y = 12\ 000$, $Z = 4\ 000$
 E_{max} : 100 kg, 300 kg, 500 kg, 5 000 kg, 10 t, 30 t and 50 t
- Group 3 Class B, $n_{LC} = 10\ 000$, $Y = 25\ 000$, $Z = 10\ 000$
 E_{max} : 500 kg, 1 000 kg and 4 000 kg

D.2.1 Summarise and sort the load cells with respect to E_{max} and accuracy as follows:

Class	Y	← lowest			E_{max} , kg		→ highest						
		n_{LC}	Group	Z	v_{min} , kg								
C3	12 000				100	300	500			5 000	10 000	30 000	50 000
3 000													
2	4 000				0,008 3	0,025	0,042			0,42	0,83	2,5	4,17
C6	18 000	50			100	300	500						
6 000													
1	6 000	0,002 8			0,005 5	0,016 7	0,028						
B10	25 000						500	1 000	4 000				
10 000													
3	10 000						0,020	0,040	0,16				

D.2.2 Identify the smallest capacity load cells in each group to be tested, according to R 60-2, 2.4:

Class	Y	← lowest			E_{max} , kg		→ highest				
		n_{LC}	Group	Z	v_{min} , kg						

C3	12 000		100	300	500			5 000	10 000	30 000	50 000
3 000											
2	4 000		0,008 3	0,025	0,042			0,42	0,83	2,5	4,17
C6	18 000	50	100	300	500						
6 000											
1	6 000	0,028	0,005 5	0,016 7	0,002 8						
B10	25 000				500	1 000	4 000				
10 000											
3	10 000				0,020	0,040	0,16				

In this example, select and identify:

C6—50 kg (full evaluation test required)

B10—500 kg (full evaluation test required)

Although load cell C3—100 kg is the smallest capacity in its group, its capacity falls within the range of other selected load cells having better metrological characteristics. Therefore, it is not selected.

D.2.3 Begin with the group with the best metrological characteristics (in this example, B10) and in accordance with R 60-2, 2.4.2, select the next largest capacity between 5 and 10 times that of the nearest smaller capacity load cell which has been selected. When no capacity meets this criterion, the selected load cell shall be that having the smallest capacity exceeding 10 times that of the nearest smaller capacity load cell which has been selected. Continue this process until all load cell capacities in the group have been considered.

Class	Y	<--- lowest				E_{max} , kg	---> highest				
n_{LC}											
Group	Z					v_{min} , kg					
C3	12 000		100	300	500			5 000	10 000	30 000	50 000
3 000											
2	4 000		0,008 3	0,025	0,042			0,42	0,83	2,5	4,17
C6	18 000	50	100	300	500						
6 000											
1	6 000	0,002 8	0,005 5	0,016 7	0,028						
B10	25 000				500	1 000	4 000				
10 000											
3	10 000				0,020	0,040	0,16				

In this example, select and identify:

B10—4 000 kg (full evaluation test required)

D.2.4 Move to the group with the next best characteristics (in this example, C6) and, in accordance with R 60-2, 2.4.2 select the next largest capacity between 5 and 10 times that of the nearest smaller capacity load cell which has been selected. When no capacity meets this criterion, the selected load cell shall be that having the smallest capacity exceeding 10 times that of the nearest smaller capacity load cell which has been selected. Continue this process until all load cell capacities in the group have been considered.

Class n_{LC} Group	Y	← lowest			E_{max} , kg		→ highest				
		Z				v_{min} , kg					
C3 3 000 2	12 000 4 000		100 0,008 3	300 0,025	500 0,042			5 000 0,42	10 000 0,83	30 000 2,5	50 000 4,17
C6 6 000 1	18 000 6 000	50 0,002 8	100 0,005 5	300 0,016 7	500 0,028						
B10 10 000 3	25 000 10 000				500 0,020	1 000 0,040	4 000 0,16				

In this example, **there is no change** to the load cells selected. The capacities of the load cells C6—300 kg and C6—500 kg exceed the capacity of the load cell C6—50 kg by greater than 5 times but not greater than 10 times. However, a 500 kg load cell of better metrological characteristics (from group B10) has already been selected. Therefore, in order to minimise the number of load cells to be tested according to R 60-2, 2.3.1, neither cell is selected.

D.2.5 Again, and repeating this process until all groups have been considered, move to the group with the next best characteristics (in this example, C3) and in accordance with R 60-2, 2.4.4, select the next largest capacity between 5 and 10 times that of the nearest smaller capacity load cell which has been selected. When no capacity meets this criterion, the selected load cell shall be that having the smallest capacity exceeding 10 times that of the nearest smaller capacity load cell which has been selected. Continue this process until all load cell capacities in the group and all groups have been considered.

Class n_{LC} Group	Y	← lowest			E_{max} , kg		→ highest				
		Z				v_{min} , kg					
C3 3 000 2	12 000 4 000		100 0,008 3	300 0,025	500 0,042			5 000 0,42	10 000 0,83	30 000 2,5	50 000 4,17
C6 6 000 1	18 000 6 000	50 0,002 8	100 0,005 5	300 0,016 7	500 0,028						

B10	25 000				500	1 000	4 000				
10 000											
3	10 000				0,020	0,040	0,16				

In this example, select and identify:

C3 — 30 000 kg (full evaluation test required) Proceeding from smallest to largest capacity, the only capacity of load cell which is greater than 5 times the capacity of an already selected load cell but less than 10 times that capacity is the C3 — 30 000 kg load cell. Since the capacity of the C3 — 50 000 kg load cell does not exceed 5 times the capacity of the next smaller selected load cell, which is C3 — 30 000 kg, according to R 60-2, 2.4.3 it is presumed to comply the requirements of this Recommendation.

D.2.6 After completing steps D.2.2 to D.2.5 and identifying the load cells, compare load cells of the same capacity from different groups. Identify the load cells with the highest accuracy class and highest n_{LC} in each group (see shaded portion of table below). For those load cells of the same capacity but from different groups, identify only the one with the highest accuracy class and n_{LC} and lowest v_{min} .

Class	Y	← lowest			E_{max} , kg		→ highest				
		n_{LC}	Z	Group	v_{min} , kg						
C3	12 000										
3 000											
2	4 000		0,008 3	0,025	0,042			0,42	0,83	2,5	4,17
C6	18 000	50	100	300	500						
6 000											
1	6 000	0,002 8	0,005 5	0,016 7	0,028						
B10	25 000				500	1 000	4 000				
10 000											
3	10 000				0,020	0,040	0,16				

Inspect the values of v_{min} , Y, and Z for all cells of the same capacity.

If any load cell of the same capacity has a lower v_{min} or higher Y than the identified load cell, that load cell (or load cells) is also liable for partial evaluation testing, specifically the conduct of additional temperature effect on minimum dead load, E_{min} and barometric pressure effect tests.

If any load cell of the same capacity has a higher Y than the selected load cell, that load cell (or load cells) is also liable for partial evaluation testing, specifically the conduct of additional creep and DR tests.

In this example, the **load cells identified above also have the best characteristics of lowest v_{min} , highest Y and highest Z**. This is normally the case, but not always.

D.2.7 If applicable, select the load cell for humidity testing in accordance with R 60-2, 2.4.5, that being the load cell with the most severe characteristics, for example the greatest value of n_{LC} or the lowest value of v_{min} .

In this example, the load cell with the greatest value of n_{LC} or the lowest value of v_{min} is the same load cell, therefore select:

B10 — 500 kg (humidity test required)

Note: The other B10 load cells also possess the same qualifications and are possible choices. The 500 kg load cell was chosen because it is the smallest of the applicable B10 capacities. Although the C6 — 50 kg load cell has the lowest v_{min} of 0,002 8, the B10 load cells have the highest n_{LC} , highest accuracy class, and the highest Y and Z .

D.2.8 If applicable, select the load cell for the additional tests to be performed on digital load cells in accordance with R 60-2, 2.4.6, that being the load cell with the most severe characteristics, for example the greatest value of n_{max} or the lowest value of v_{min} .

2+h| **D.2.9** Summarising, the load cells selected for test are:

<i>Summary</i>	<i>Selected cells</i>
Load cells requiring full evaluation test	C6 — 50 kg B10 — 500 kg B10 — 4 000 kg C3 — 30 000 kg
Load cells requiring partial evaluation test	None
Load cell to be tested for humidity	B10 — 500 kg
Digital load cells for additional tests	None

In this example, no load cell in the family is equipped with electronics.

Annex E (Informative)

Load transmission to the load cell

This Annex is taken from the WELMEC 2.4 (European cooperation in legal metrology) Guide for Load Cells (Issue 2, published in August, 2001). With permission from WELMEC, the following portion of that Guide is reprinted here to provide guidelines for load cell evaluators, during load cell performance evaluations. Recognising the critical role that load cell receptors and load transmission devices play in accurate measurements, this Annex is intended to provide information regarding the effect of load transmission and recommendations for test design and procedure. The annex is informational and not to be considered required practice.

For some types of load cells, the kind of load transmission to the load cell has an influence on the measurements and therefore on the test results.





In this Annex the standard load transmission devices are listed.

The manufacturer should define whether the load cell works with all standard load transmission devices for the type of load cell or with selected standard load transmission devices or with a load cell specific load transmission devices.

This information may be considered for the load cell tests and may be marked on the certificate.

Standard load transmission devices

Tables E.1 and E.2 identify different types of LCs, (compression, tension, ...) and typical load cell mounting devices suitable for them. The symbols below classify the mobility between one point of contact on the load cell and its counterpart on the load receptor or mounting base.

Symbol	Description
 Figure E.1	Movement possible normal to load axis <i>Note 1:</i> allows for temperature dilatation
 Figure E.2	Movement possible normal to load axis, with reversing force (spring-back effect) <i>Note 2:</i> allows for temperature dilatation, also used for damping of lateral shock
 Figure E.3	Inclination possible <i>Note 3:</i> allows for tilt of load cell or deflection of load receptor, no movement normal to load axis possible
 Figure E.4	Indicates auto-centring effect of the complete mounting assembly of one load cell

Remarks on the standard load transmission devices presented in Tables E.1 and E.2 :

All combinations of load cell and transmitting device shown in Tables E.1 and E.2 can also be utilised in a completely reversed manner.

The load transmission device is independent of the encapsulation, potting or housing which are shown in the examples.

a) Compression LCs (Table E.1, upper part)

- The load transmissions 1 to 8 are presented for canister type LCs. Instead, all load transmissions may be constructed for S-type or ring type load cells.
- 6a shows a pendulum construction build as a complete unit.
- 6b and 6c show external pendulum rocker pins combined with ring-type LCs.
- The bearings for all compression load cells may be installed either below or above the LC.

b) Tension LCs (Table E.1, lower part)

- The load transmissions 1 and 2 are presented for canister type LCs. Alternatively, both load transmissions may be used for S-type LCs.

c) Beam LCs (Table E.2, upper part)

- The drawings present double bending and shear beams, as well as plastic potted and encapsulated constructions; all these constructions may be combined with either of the load transmissions 1 to 10.
- The direction of loading, which is given by the manufacturer, has to be observed.

d) Single point LCs (Table E.2, middle part)

- The load transmissions 1 to 10 for the beam LCs may be applied to all single point LCs.
- The direction of loading, which is given by the manufacturer, has to be observed.

e) Double bending beam LCs (Table E.2, lower part)

- The table shows examples of common constructions. Variations are possible provided the constructions allow enough horizontal flexibility between both ends.
- The direction of loading, provided by the manufacturer, has to be observed.

The single bending beams had been exempted for general acceptance, because very small displacements of the “force transducing point” may lead to a change of span and linearity.

Table E.1 — Schematic drawings for compression and tension LCs

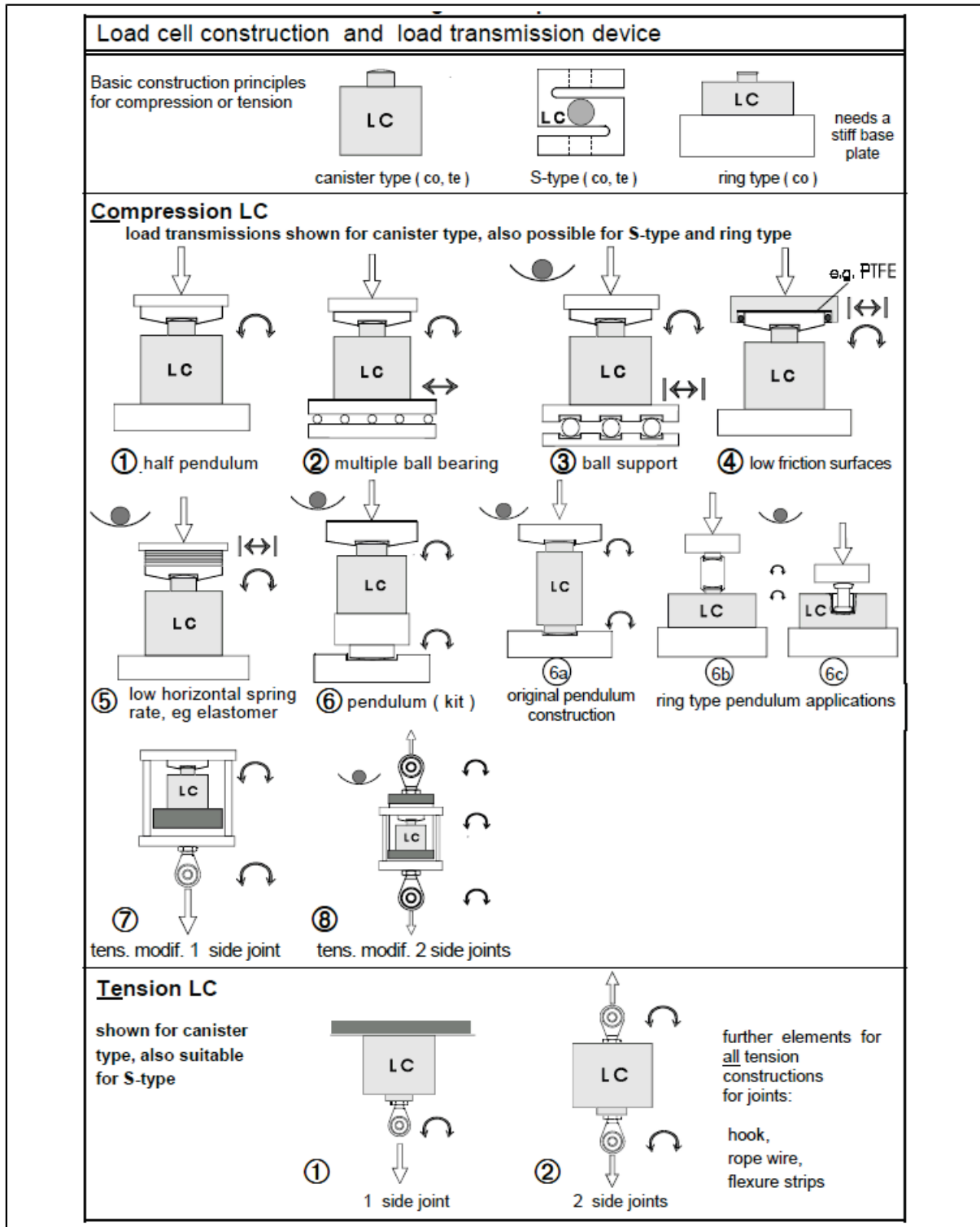

Table E.2 — Schematic drawings for beam LCs

Load cell construction and load transmission device The load transmission device is independent of the encapsulation, potting or housing and the mounting at the fixed end shown below	
Beam LC - Cantilever beam Double bending beam & Shear beam LC	
Single point LC	<p>The single point LC has no degree of freedom for horizontal displacement or inclination, using more than one LC in a load receptor decoupling elements are necessary. The load transmissions 1 to 10 for the beam LCs may be applied. Max. platform dimensions may be mentioned in the TC or the TAC.</p>
Double ended beam LC	
Constructions with fixed clamping at the two ends need for minimum displacement and inclination some elasticity of the supporting construction.	

Annex F

(Informative)

Bibliography

- [1] ISO 8601:2004¹⁾, *Data elements and interchange formats — Information interchange — Representation of dates and times*
- [2] IEC 60068-2-78:2012, *Environmental testing — Part 2-78: Tests — Test Cab: Damp heat, steady state*
- [3] IEC 60068-3-4:2001, *Environmental testing — Part 3-4: Supporting documentation and guidance — Damp heat tests*
- [4] IEC 61000-4-11:2020, *Electromagnetic compatibility (EMC) — Part 4-11: Testing and measurement techniques — Voltage dips, short interruptions and voltage variations immunity tests for equipment with input current up to 16 A per phase*
- [5] IEC 61000-4-1:2006, *Electromagnetic compatibility (EMC) — Part 4-1: Testing and measurement techniques — Overview of IEC 61000-4 series*
- [6] IEC 61000-4-29:2000, *Electromagnetic compatibility (EMC) — Part 4-29: Testing and measurement techniques — Voltage dips, short interruptions and voltage variations on d.c. input power port immunity tests*
- [7] IEC 61000-4-2:2008, *Electromagnetic compatibility (EMC) — Part 4-2: Testing and measurement techniques — Electrostatic discharge immunity test*
- [8] IEC 61000-4-3:2020, *Electromagnetic compatibility (EMC) — Part 4-3 : Testing and measurement techniques — Radiated, radio-frequency, electromagnetic field immunity test*
- [9] IEC 61000-4-4:2012, *Electromagnetic compatibility (EMC) — Part 4-4: Testing and measurement techniques — Electrical fast transient/burst immunity test*
- [10] IEC 61000-4-5:2014, *Electromagnetic compatibility (EMC) — Part 4-5: Testing and measurement techniques — Surge immunity test*
- [11] IEC 61000-4-6:2013, *Electromagnetic compatibility (EMC) — Part 4-6: Testing and measurement techniques — Immunity to conducted disturbances, induced by radio-frequency fields*
- [12] IEC 61000-6-1:2016, *Electromagnetic compatibility (EMC) — Part 6-1: Generic standards — Immunity standard for residential, commercial and light-industrial environments*
- [13] IEC 61000-6-2:2016, *Electromagnetic compatibility (EMC) — Part 6-2: Generic standards — Immunity standard for industrial environments*

1) Cancelled and replaced by ISO 8601-1:2019.

- [14] IEC 60068-2-30:2005, *IEC Publication 60068-2-30:2005 Environmental testing — Part 2-30: Tests — Test Db: Damp heat, cyclic (12 h + 12 h cycle)*
- [15] IEC 61000-2-1:1990, *IEC Publication 61000-2-1:1990 Electromagnetic compatibility (EMC) — Part 2: Environment — Section 1: Description of the environment — Electromagnetic environment for low-frequency conducted disturbances and signalling in public power supply systems*
- [16] OIML-CS, Procedural Document PD-05 (Edition 2) *Processing an OIML Type Evaluation Report and OIML Certificate*
- [17] OIML G 1-100:2008, *Guide to the Expression of Uncertainty in Measurement, BIPM, IEC, IFCC, ISO, IUPAC, IUPAP, OIML*
- [18] OIML V 2:2013, *International Vocabulary of Terms in Legal Metrology (VIML)*
- [19] OIML V 2-200:2012, *International Vocabulary of Metrology — Basic and General Concepts and Associated Terms (VIM)*
- [20] OIML D 9:2004, *Principles of metrological supervision*
- [21] OIML D 11:2008, *General requirements for electronic measuring instruments*
- [22] OIML B 18:2018, *Framework for the OIML Certification System (OIML-CS)*
- [23] OIML D 31:2008, *General requirements for software controlled measuring instruments*
- [24] OIML R 50:2014, *OIML R 50:2014 Continuous totalizing automatic weighing instruments (belt weighers)*
- [25] OIML R 51:2006, *Automatic catchweighing instruments*
- [26] OIML R 61:2017, *Automatic gravimetric filling instruments*
- [27] OIML R 76:2006, *Non-automatic weighing instruments*
- [28] OIML R 106, *Automatic rail-weighbridges*