

INTERNATIONAL
DOCUMENT

OIML D 36

Edition 2020 (E)

Pipe provers for verification and calibration of
measuring systems for liquids

Tubes étalons pour vérification et étalonnage des ensembles de mesurage de
liquides



Contents

Foreword		4
Introduction		5
1 Scope		7
2 Terms and definitions		7
3 Pipe provers covered by this Document		8
3.1 General.....		8
3.2 Types of pipe provers.....		8
3.3 Accuracy.....		8
3.4 Construction of pipe provers.....		9
4 Calibration of pipe provers		10
4.1 General.....		10
4.2 Reference conditions.....		10
4.3 Methods for calibrating pipe provers.....		10
5 General requirements for the calibration and verification of measuring systems using a pipe prover		11
5.1 Test liquids.....		11
5.2 Base volume of the pipe prover.....		11
5.3 Temperature measurement.....		11
5.4 Pressure measurement.....		11
5.5 Inspection of electronic devices.....		11
5.6 Preliminary runs.....		11
5.7 Test flowrates.....		11
5.8 Number of test runs.....		11
5.9 Calculation of errors.....		12
Annex A Example of test procedures for the verification of measuring systems.....		14
Bibliography		23

Foreword

The International Organisation of Legal Metrology (OIML) is a worldwide, intergovernmental organisation whose primary aim is to harmonise the regulations and metrological controls applied by the national metrological services, or related organisations, of its Member States.

The main categories of OIML publications are:

- **International Recommendations (OIML R)**, which are model regulations that establish the metrological characteristics required of certain measuring instruments and which specify methods and equipment for checking their conformity. OIML Member States shall implement these Recommendations to the greatest possible extent;
- **International Documents (OIML D)**, which are informative in nature and which are intended to harmonise and improve work in the field of legal metrology;
- **International Guides (OIML G)**, which are also informative in nature and which are intended to give guidelines for the application of certain requirements to legal metrology; and
- **International Basic Publications (OIML B)**, which define the operating rules of the various OIML structures and systems.

OIML Draft Recommendations, Documents and Guides are developed by Project Groups linked to Technical Committees or Subcommittees which comprise representatives from the Member States. Certain international and regional institutions also participate on a consultation basis. Cooperative agreements have been established between the OIML and certain institutions, such as ISO and the IEC, with the objective of avoiding contradictory requirements. Consequently, manufacturers and users of measuring instruments, test laboratories, etc. may simultaneously apply OIML publications and those of other institutions.

International Recommendations, Documents, Guides and Basic Publications are published in English (E) and translated into French (F) and are subject to periodic revision.

Additionally, the OIML publishes or participates in the publication of **Vocabularies (OIML V)** and periodically commissions legal metrology experts to write **Expert Reports (OIML E)**. Expert Reports are intended to provide information and advice, and are written solely from the viewpoint of their author, without the involvement of a Technical Committee or Subcommittee, nor that of the CIML. Thus, they do not necessarily represent the views of the OIML.

This publication—reference OIML D 36, edition 2020 (E)—was developed by Project Group 8 of OIML TC 8 *Measurement of quantities of fluids*. It was approved for final publication by the International Committee of Legal Metrology in 2020 and will be submitted to the International Conference on Legal Metrology in 2021 for formal sanction. It supersedes OIML R 119 dated 1996.

OIML Publications may be downloaded from the OIML website in the form of PDF files. Additional information on OIML Publications may be obtained from the Organisation's headquarters:

Bureau International de Métrologie Légale
11, rue Turgot — 75009 Paris — France
Telephone: 33 (0)1 48 78 12 82
Fax: 33 (0)1 42 82 17 27
E-mail: biml@oiml.org
Internet: www.oiml.org

Introduction

A pipe prover is a measuring system that is used as a measurement standard for volume or for measuring the flowrate of liquid. These systems have advantages over other conventional measurement methods for precise volumetric measurement using a calibrated base volume, a semi-automatic measurement in a production/calibration line, and continuous measurement without interrupting the flow (for certain types of provers).

Because of these advantages, pipe provers are widely used as standards to calibrate/verify flow meters or as capacity measures for liquids, including water and oil. The users of these instruments include national/local metrology institutes, calibration laboratories, manufacturers of measuring instruments, water utilities, food industries, and oil/chemical industries.

This Document may be used in conjunction with other International Recommendations and standards such as OIML R 49-1:2013, OIML R 49-2:2013, OIML R 49-3:2013, OIML D 35:2020, OIML R 117-1:2019, OIML R 117-2:2019, OIML R 117-3:2019, ISO 91:2017, ISO 4267-2:1988, ISO 7278-1:1987, ISO 7278-2:1988¹⁾, ISO 7278-3:1998, ISO 7278-4:1999¹⁾ and ISO 8222:2020.

1) Cancelled and replaced by ISO 7278-2:2022.

Part -

1 Scope

This Document covers provers, including piston provers, which are used as standards to verify and/or calibrate measuring equipment/systems for volume or for measuring the flowrate of liquids. These processes for verification/calibration are conducted in compliance with the metrological requirements in the relevant OIML Recommendations or other international standards. This Document proposes model technical requirements for the design, installation, calibration, and use of provers in legal metrology and in industries involved in flow and volume measurements.

2 Terms and definitions

The general terms used in this Document are in accordance with the *International Vocabulary of Metrology—Basic and General Concepts and Associated Terms* (VIM), OIML V 2-200:2012, and the *International Vocabulary of Terms in Legal Metrology* (VIML), OIML V 1:2013. Other terms specific to this Document are defined below.

2.1 base volume

constant reference volume that corresponds to the displacement of a full stroke of the displacer in the calibrated section

Note: A base volume is usually equivalent to the volume of the calibrated section.

2.2 calibrated section

specified section in a prover defined with a pipe (or cylinder) and displacer(s) that has a constant crosssectional area

Note: The volume inside a calibrated section, when it has been accurately determined in advance, may be used to define the base volume of the pipe prover.

2.3 detector

contact sensor or a non-contact (optical or mechanical) sensor that is used to detect the position of the displacer

Note: A mechanical detector using a cantilever is often employed in certain pipe provers. The lever is pushed by the displacer and actuates an electrical switch installed outside the pipe wall. A linear encoder is used for a piston prover to transmit a pulse signal that is proportional to the displacement of the displacer.

2.4 displacer

object (usually a sphere or a piston) that travels along with the liquid flowing through the prover and that is used to define the calibrated section

3 Pipe provers covered by this Document

3.1 General

A pipe prover is a pipe or cylinder whose volume is used to verify and/or calibrate flow measuring systems for liquids. A process of calibration is accomplished by a displacer (usually a sphere or piston) passing through the pipe that actuates a pair of position detectors defining the calibrated section within a certain time. The known volume of this section (base volume) is used as a standard to determine the instrumental error of the measuring system which is connected to the prover. The measured volume is corrected for the errors due to the differences in temperature and pressure of the liquid from the reference condition. The travel time between the detectors is used to determine the flowrate.

3.2 Types of pipe provers

The following are generally used as pipe provers. Other types of pipe provers can be used when their metrological characteristics comply with the requirements of this Document.

3.2.1 Uni-directional type

A uni-directional type of prover uses a displacer that travels in one direction to actuate detectors in the calibrated section of the pipe (see Figure A.1). The measured volume corresponds to one passage of the displacer.

3.2.2 Bi-directional type

A bi-directional type of prover uses a displacer that travels in one direction and then in the opposite direction through the same calibrated section (see Figures A.2 and A.3). The measured volume corresponds to the sum of both passages of the displacer. One pair or two independent pairs of detectors are used to record the movement of the displacer.

3.2.3 Small volume or compact type

A small volume or compact type of prover uses a displacer which travels through a very short section of the pipe or cylinder (see Figures A.4 and A.5). The volume displaced in the calibrated section is usually much smaller than that of a conventional prover (such as in 3.2.1 and 3.2.2). For this reason, highprecision detectors and a method for pulse-interpolation are necessary to achieve good repeatability and high accuracy.

3.2.4 Full stroke type

This type of pipe prover uses the standing start and stop method (see Figure A.6). Its base volume is the volume displaced by a single full stroke of the reversible displacer. The full stroke type may be used mainly for the verification of LPG dispensers.

3.3 Accuracy

The calibration of the base volume of a prover shall be carried out such that the expanded uncertainty of the calibration is significantly smaller than the acceptable criteria which is referred to as the maximum permissible error (MPE) in type approval tests and verification tests. The treatment of the expanded uncertainty and the acceptance criteria should follow OIML G 19:2017, the applicable OIML Recommendation, and/or an international standard. The expanded uncertainty shall be determined using an appropriate coverage factor (k) which is usually equivalent to two ($k = 2$).

3.4 Construction of pipe provers

3.4.1 General

The construction of pipe provers should meet the provisions of ISO 4267-2:1988. Typical layouts of pipe provers are shown in Figures A.1 to A.5 . Special care should be taken in the control system of a prover for the collection of necessary data. For the purposes of correct metrological control, some requirements are mentioned below.

3.4.2 Materials and fabrication

The materials of construction and the pressure rating of the prover should be compatible with the measuring systems to be verified/calibrated and the test liquids. The prover should be thermally insulated for the required duty and operational conditions. If separation of prover components is necessary (e.g. for transportation), the correct reassembly of the components shall be ensured by an appropriate reconstruction and by a recalibration of the base volume. Internal coating of the prover with the correct material should be used to reduce corrosion and wear.

3.4.3 Displacer

In general, provers use one or more spheres, or a piston as the displacer. Spheres should be made of a resilient material that is compatible with the test liquids, and they shall meet the specified minimum and maximum sizes. Piston displacers shall be made of rigid material with resilient seals that are in contact with the pipe prover wall. The diameter of the sphere(s) shall be such that a seal is provided without excessive friction.

3.4.4 Valves

The valves used in a pipe-prover system shall not leak, as their leakage would influence the measurement result. Means for checking possible leakage in the system shall be provided.

3.4.5 Temperature measuring devices

Temperature measuring devices with an appropriate range shall be installed at the inlet and outlet of the prover. These devices shall be immersed in the liquid to enable an accurate determination of the liquid temperature. The use of thermo-wells (tubular fittings used to protect the temperature sensors) is normally recommended. The accuracy and range of the devices shall be such that the provisions of 3.3 and 5.3 are met.

3.4.6 Pressure measuring devices

Pressure measuring devices with an appropriate range shall be used to correctly measure pressure in the prover. The accuracy and range of the devices shall be such that the provisions of 3.3 and 5.4 are met.

3.4.7 Detectors

Detection devices and switches for any given direction of the displacer shall respond to the displacer's position such that the prover meets the performance requirements specified in 3.3.

3.4.8 Vent valve and related piping

Vent valves shall be installed on the topmost part of the pipe to ensure that all the gas is vented from the dead spaces not swept by the displacer. This requirement ensures that the piping, the pipe prover and the meter being verified/calibrated remain completely filled with liquid. Provisions shall be made for

the draining of liquids and for venting vapours from the prover. If the prover is intended to be calibrated using the water draw method or the master meter method, correct connections shall be provided.

4 Calibration of pipe provers

4.1 General

The calibration methods summarised below are to be used as a guideline. A detailed description of these calibration methods is also given in ISO 7278-2:1988. National regulations should specify that pipe provers are to be calibrated when they are installed, and that they should be re-calibrated periodically at an interval fixed by these regulations. Pipe provers should also be re-calibrated when they have been repaired or modified (e.g. change of detectors, recoating, dismantling and/or re-installation).

4.2 Reference conditions

The base volume of a pipe prover shall be determined on the basis of the reference conditions specified in national/regional regulations.

4.3 Methods for calibrating pipe provers

There are three methods for calibrating a pipe prover: the water draw method, the master meter method, and the dimensional method.

4.3.1 Water draw method

The calibration of a pipe prover by the water draw method requires standard capacity measures (volumetric method) or a weighing instrument with a tank (gravimetric method) to determine the base volume of the prover. To allow a continuous and uniform flowrate to be produced, the base volume of the prover may be transferred into a holding tank using arrangements such as those shown in Figures A.7 and A.8. This volume is then measured either gravimetrically or volumetrically by transferring the liquid into standard capacity measures. The prover shall be thoroughly flushed and cleaned before calibration.

4.3.2 Master meter method

Firstly, a master meter for flowrate is calibrated by another flow or volume reference standard. Secondly, a pipe prover under calibration is calibrated using the master meter, where the master meter functions merely as an intermediate link between the reference standard and the prover under calibration. Therefore, before and after the calibration, it is necessary to assure that the performance of the master meter is stable by using the reference standard. A typical arrangement of the master meter method is shown in Figure A.9.

Note: This method is not applicable to a full stroke type of pipe prover with a small volume. Another calibrated master prover may be used for the reference standard.

4.3.3 Dimensional method

This method is based on accurate dimensional measurements of the calibrated section of the pipe prover. The measurements are typically conducted by evaluating effective and averaged values for the inner length and the inner diameter of the calibrated section of the cylinder. This method is particularly effective to reduce measurement uncertainty for piston provers and other straight-tube provers.

5 General requirements for the calibration and verification of measuring systems using a pipe prover

5.1 Test liquids

A measuring system shall be tested using one of the liquids marked on the data plate (or in the instruction manual) of the measuring system, or with a liquid whose flow characteristics are within the ranges of those of the marked liquids. All appropriate safety and environmental measures concerning the handling of the liquids shall be observed.

5.2 Base volume of the pipe prover

It shall be ensured that the base volume of the pipe prover is matched to the resolution of the measuring system and is adequate to meet the requirements of 3.3. If the measuring system is equipped with a pulse generator which does not generate enough pulses for the base volume, a pulse-interpolation method may be used in compliance with ISO 7278-3:1998.

5.3 Temperature measurement

Appropriate temperature-measuring devices shall be used to ensure accurate temperature correction of the liquid volume. These devices shall be mounted in suitable locations on the prover and the measuring system. It is recommended to use the temperature-measuring devices with an expanded uncertainty of 0,2 °C or less. Calibration certificates shall be provided for the devices.

5.4 Pressure measurement

Appropriate pressure-measuring devices (e.g. pressure gauges) shall be used to ensure accurate pressure correction of the liquid volume. The devices shall be mounted in a suitable location on the prover and on the measuring system in order to measure the pressure of the liquid with the necessary accuracy. It is recommended to use the pressure-measuring devices with an expanded uncertainty of 0,05 MPa (0,5 bar) or less. Calibration certificates shall be provided for the devices.

5.5 Inspection of electronic devices

The electronic devices including detectors, pulse generator, and pulse counter shall be inspected to ensure correct operation.

5.6 Preliminary runs

A sufficient number of preliminary runs shall be carried out before the actual verification/calibration runs in order to ensure complete elimination of any gases, which may be contained in the prover and associated piping, and to ensure that the liquid temperature is stable and uniform. The measuring system shall be checked to ensure that leaks do not exist.

5.7 Test flowrates

The total number and the range of flowrates applied for verification/calibration are specified in the applicable OIML Recommendation(s) for the measuring system.

5.8 Number of test runs

The number of runs to be carried out at a particular flowrate is specified in the applicable OIML Recommendation(s) for the measuring system. In general, the number of runs is more than two in order

to ensure the good repeatability of the measuring system as well as to verify whether each result meets the maximum permissible error (MPE).

5.9 Calculation of errors

The errors of the measuring system may be calculated either

- from the meter factor determined according to ISO 4267-2:1988, Clause 7, or
- from the following equations in which the second order terms are neglected:

$$E = E' + E_{\alpha} + E_{\beta} + E_{\gamma} + E_{\delta} \quad (1)$$

$$E' = [(V_{lm} - V_B) / V_B] \times 100 \quad (2)$$

$$E_{\alpha} = \alpha \times (t_{lp} - t_{lm}) \times 100 \quad (3)$$

$$E_{\beta} = \beta \times (t_s - t_{lp}) \times 100 \quad (4)$$

$$E_{\gamma} = \gamma \times (p_{lm} - p_{lp}) \times 100 \quad (5)$$

$$E_{\delta} = -\delta \times p_{lp} \times 100 \quad (6)$$

where

E	is the instrumental error of the measuring system, in %
E'	is the uncorrected error, in %
E_{α}	is the temperature correction for the test liquid, in %
E_{β}	is the temperature correction for the pipe prover, in %
E_{γ}	is the pressure correction for the test liquid, in %
E_{δ}	is the pressure correction for the pipe prover, in %
V_{lm}	is the volume indicated by the meter, in L
V_B	is the base volume of the pipe prover, in L
t_{lp}	is the liquid temperature in the pipe prover, in °C
t_{lm}	is the liquid temperature in the meter, in °C
t_s	is the reference temperature of the pipe prover, in °C
p_{lp}	is the gauge pressure of the liquid in the pipe prover, in kPa
p_{lm}	is the gauge pressure of the liquid in the meter, in kPa
α	is the cubic expansion coefficient of the test liquid due to temperature, in °C ⁻¹
β	is the cubic expansion coefficient of the pipe prover due to temperature, in °C ⁻¹
γ	is the compression coefficient of the test liquid, in kPa ⁻¹
δ	is the pressure expansion coefficient of pipe prover, in kPa ⁻¹

Note: The four coefficients may be determined as shown below:

α	Refer to OIML D 35:2020 or ISO 91:2017 for petroleum products; refer to ISO 8222 for water
----------	--

- β $33 \times 10^{-6} \text{ } ^\circ\text{C}^{-1}$ for mild steel, $51 \times 10^{-6} \text{ } ^\circ\text{C}^{-1}$ for stainless steel
 γ Refer to the coefficient C_{pl} of ISO 4267-2:1988, 5.4
 δ Refer to the coefficient C_{ps} of ISO 4267-2:1988, 5.3

To obtain a more accurate result, the following equation can be used without neglecting the second order terms:

$$E = \left(\frac{V_{lm}}{V_B} \cdot \frac{[1 - \alpha(t_{lm} - t_{lp})][1 + \gamma(p_{lm} - p_{lp})]}{[1 + \beta(t_{lp} - t_s)](1 + \delta_{lp})} - 1 \right) \times 100 \quad (7)$$

Annex A

(Informative)

Example of test procedures for the verification of measuring systems

This Annex describes examples of typical verification procedures using pipe provers. It should be noted that there are many other applicable test methods described in OIML Recommendations and ISO Standards. All verification procedures should comply with the provisions of this Document.

A.1 Test procedure for measuring systems for liquid fuel

Two typical installations, in which a pipe prover and a measuring system for liquid fuel are connected, are shown in Figures A.10 and A.11 . The basic test procedure for these systems is as follows:

- a) Carry out a sufficient number of preliminary runs.
- b) Locate the displacer at the starting position, reset the pulse counter and interval timer.
- c) Start the displacer in movement. Ensure that both the pulse counter and the interval timer start when the start detector is activated.
- d) While counting pulses, read and record the temperature and pressure of the pipe prover and the measuring system.
- e) Check that both the pulse counter and the interval timer stop when the end detector is activated.
- f) Read and record the indicated results of the pulse counter and the interval timer.

A.2 Test procedure for measuring systems for LPG under pressure

A typical installation, in which a measuring system for LPG under pressure is tested using a pipe prover, is shown in Figure A.12. It should be ensured that the LPG remains in liquid phase inside the pipe prover by means of an appropriate device, if necessary. The basic test procedure shall be the same as those described in Clause A.1.

A.3 Test procedure for LPG dispensers

A typical installation, in which a full-stroke type pipe prover is used for verifying an LPG dispenser, is shown in Figure A.13. The basic test procedure is as follows:

- a) Locate the pipe prover horizontally and close to the dispenser (to make the pipework as short as possible).
- b) Connect the outlet nozzle of the dispenser to the inlet of the twin-type 3-way valve connected to the pipe prover.
- c) Position the 3-way valve to initiate the flow. Purge gas adequately and conduct preliminary runs. Check that no air bubbles are present by means of a sight glass.
- d) Locate the displacer at the starting position and reset the indication of the dispenser.
- e) Start the cylindrical piston movement.
- f) Read and record the temperature, pressure and flowrate of the liquid during flow.

- g) Read and record the volume displayed on the dispenser when the displacer reaches the end point of its stroke.

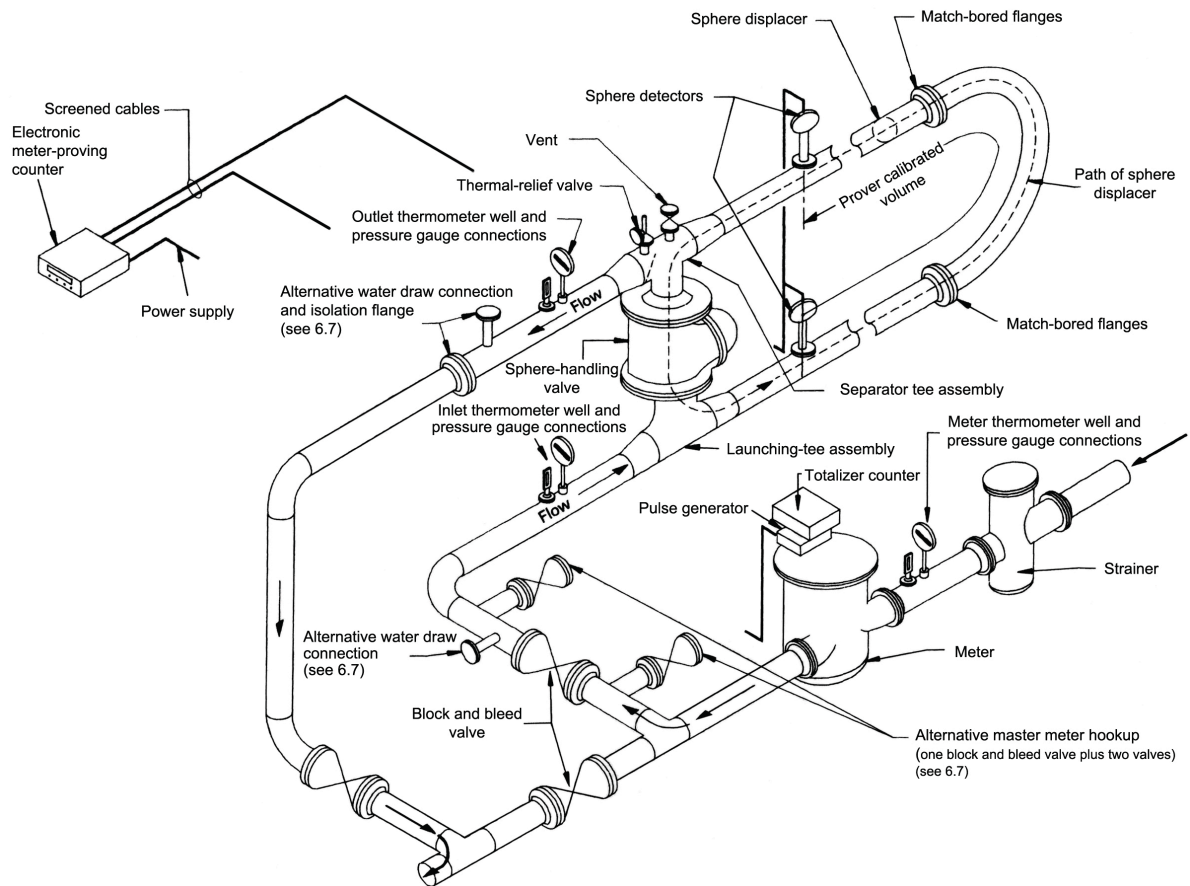

Figure A.1 — Typical uni-directional pipe prover (Extracted from ISO 7278-2:1988²⁾)

2) Figures 1 to 3b are extracted from ISO 7278-2:1988 and ISO 7278-4:1999, reproduced with the authorisation of the International Organization for Standardization (ISO) which holds the copyright.

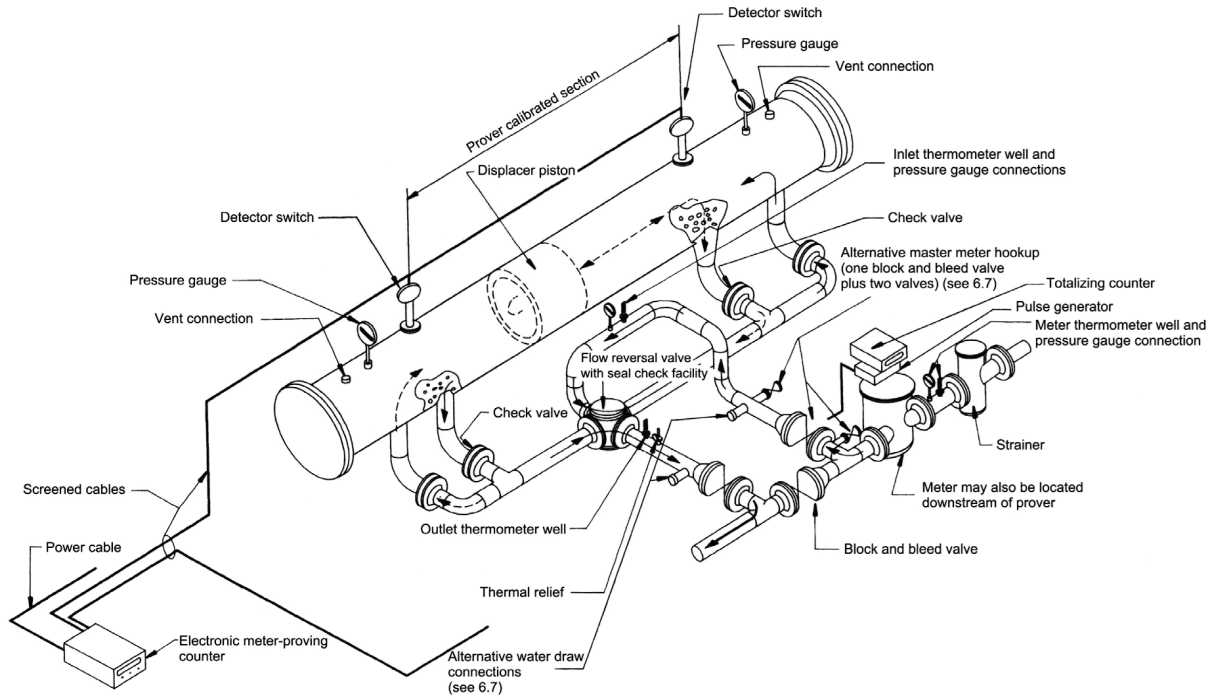

Figure A.2 — Typical bi-directional straight-type piston pipe prover (Extracted from ISO 7278-2:1988²⁾)

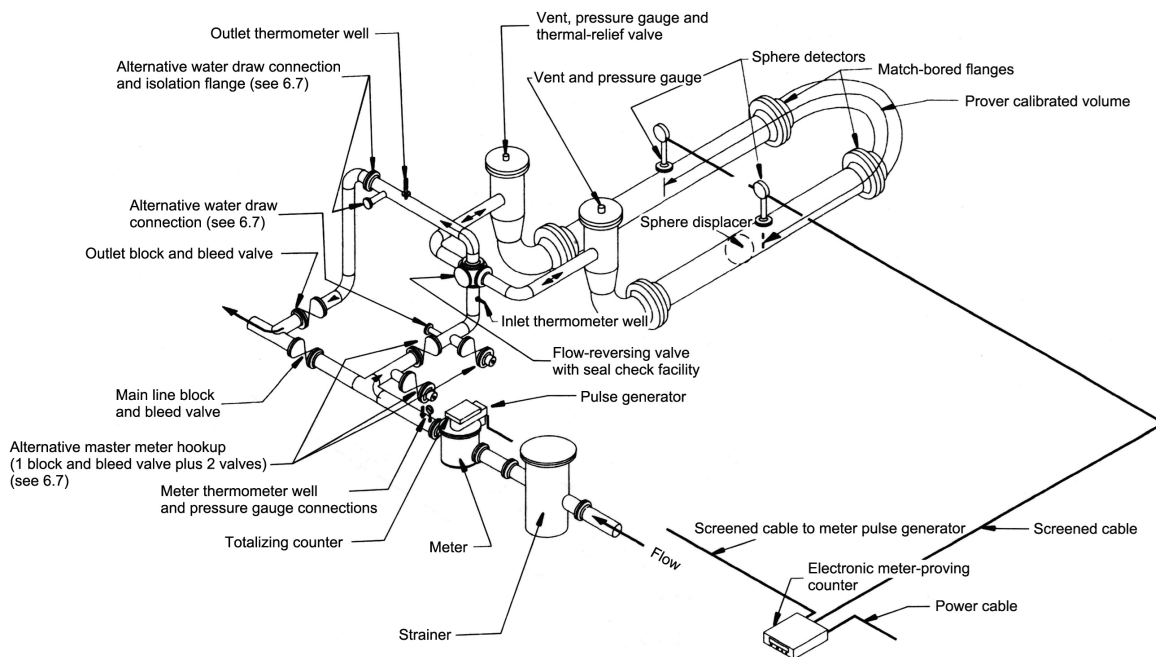

Figure A.3 — Typical bi-directional U-type pipe prover (Extracted from ISO 7278-2:1988²⁾)

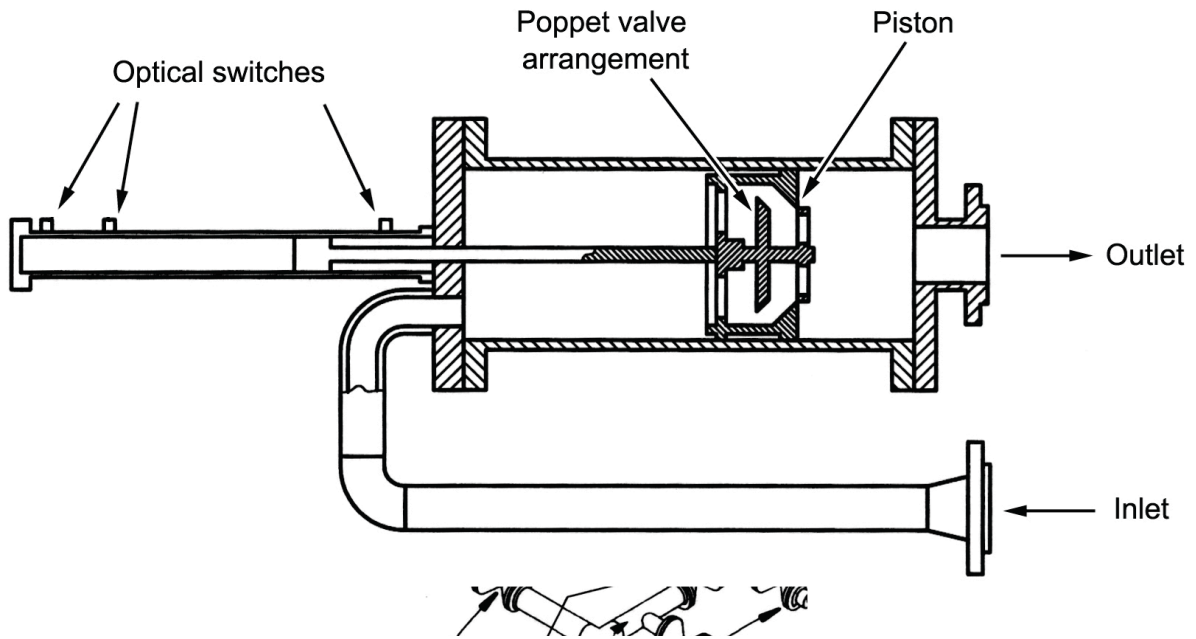

Figure A.4 — Typical small volume pipe prover with internal valve (Extracted from ISO 7278-4:1999²⁾)

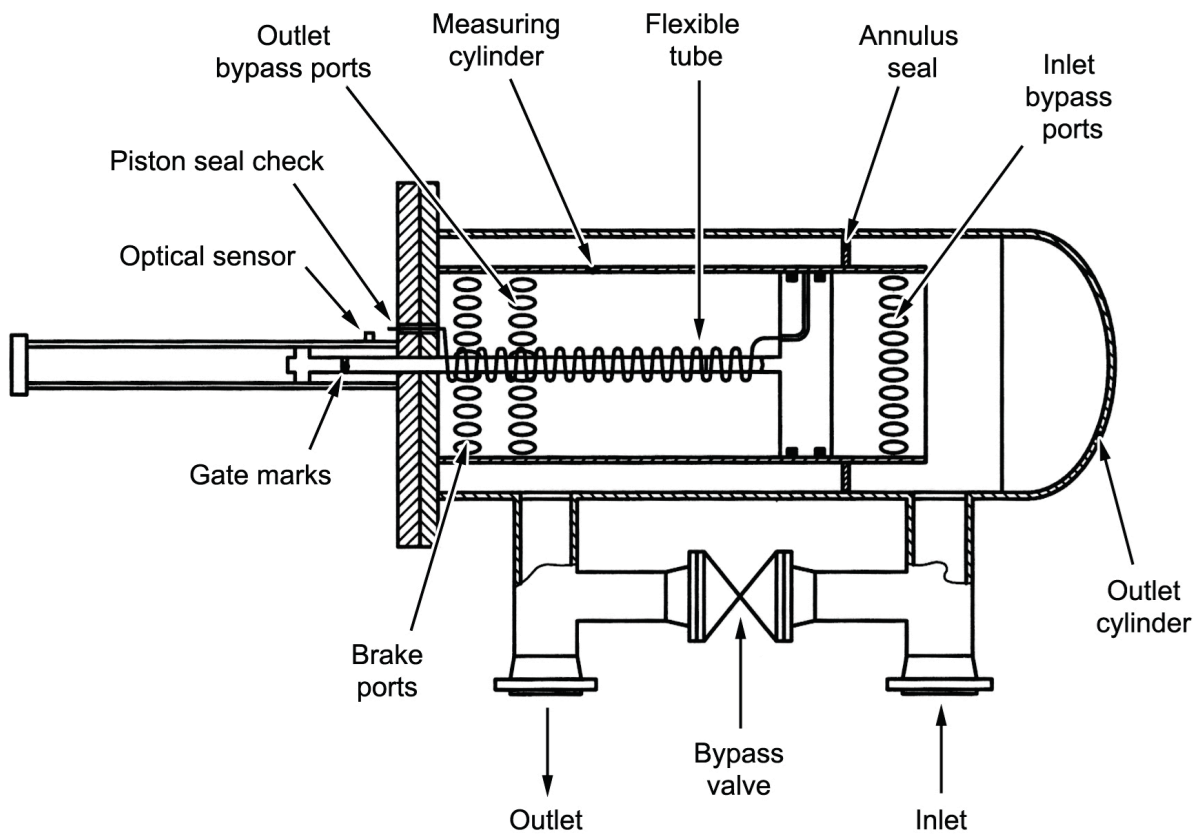

Figure A.5 — Typical small volume pipe prover with external valve (Extracted from ISO 7278-4:1999²⁾)

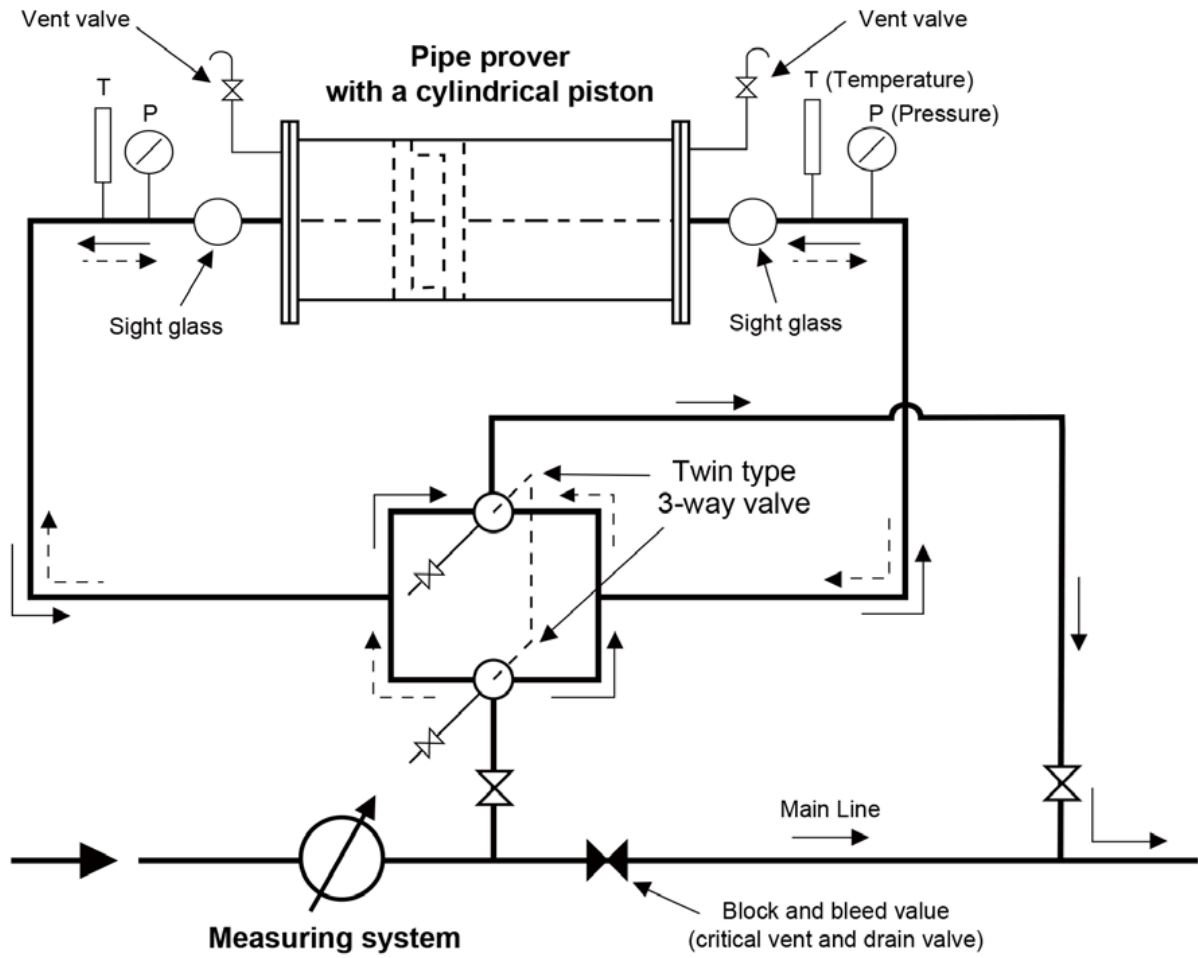

Figure A.6 — Typical full stroke type pipe prover

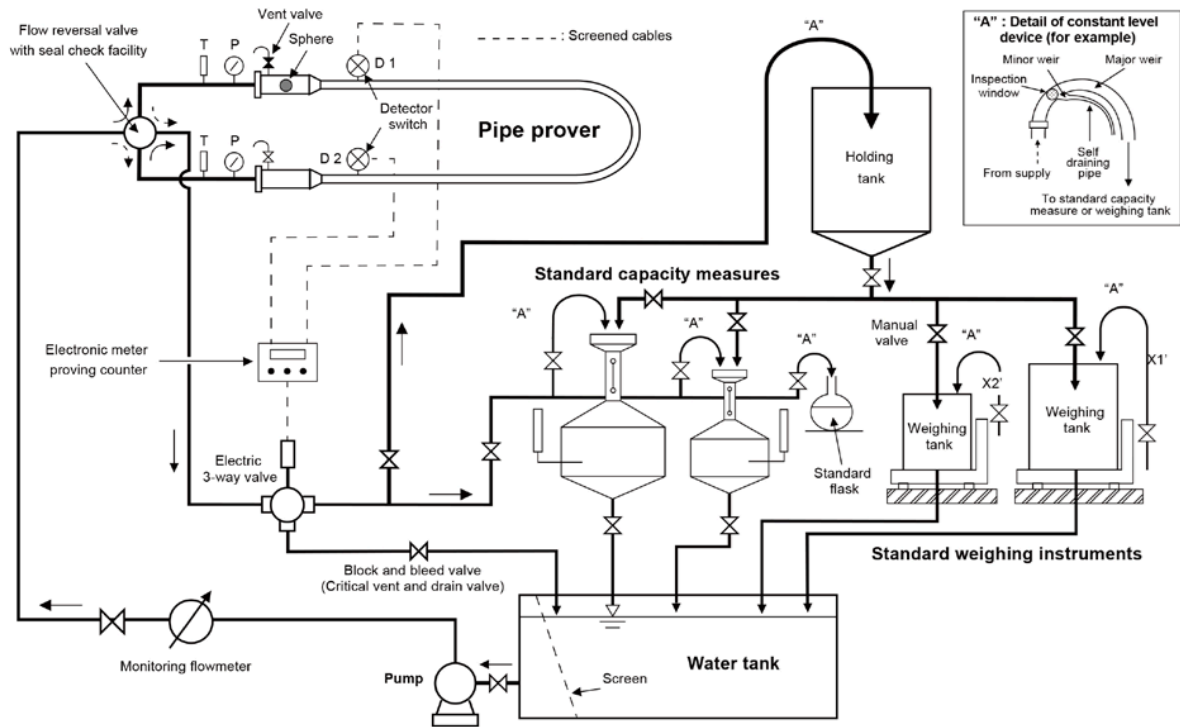

Figure A.7 — Calibration of pipe prover (water draw method)

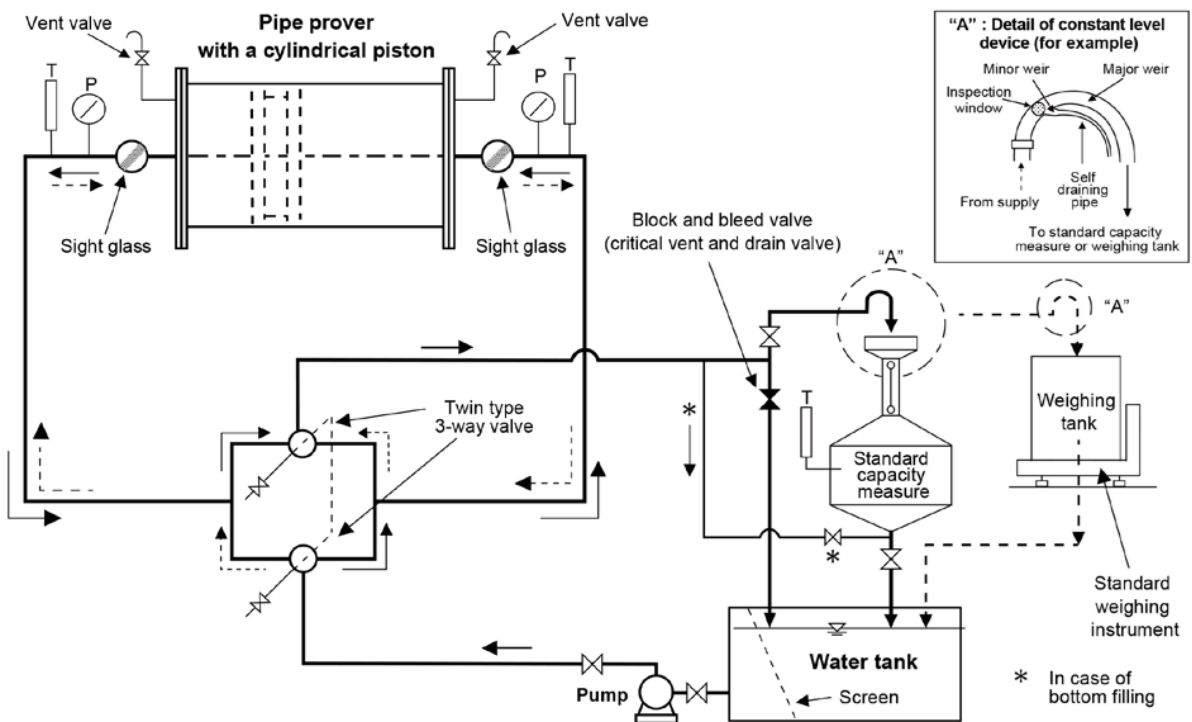

Figure A.8 — Calibration of full stroke type pipe prover (water draw method)

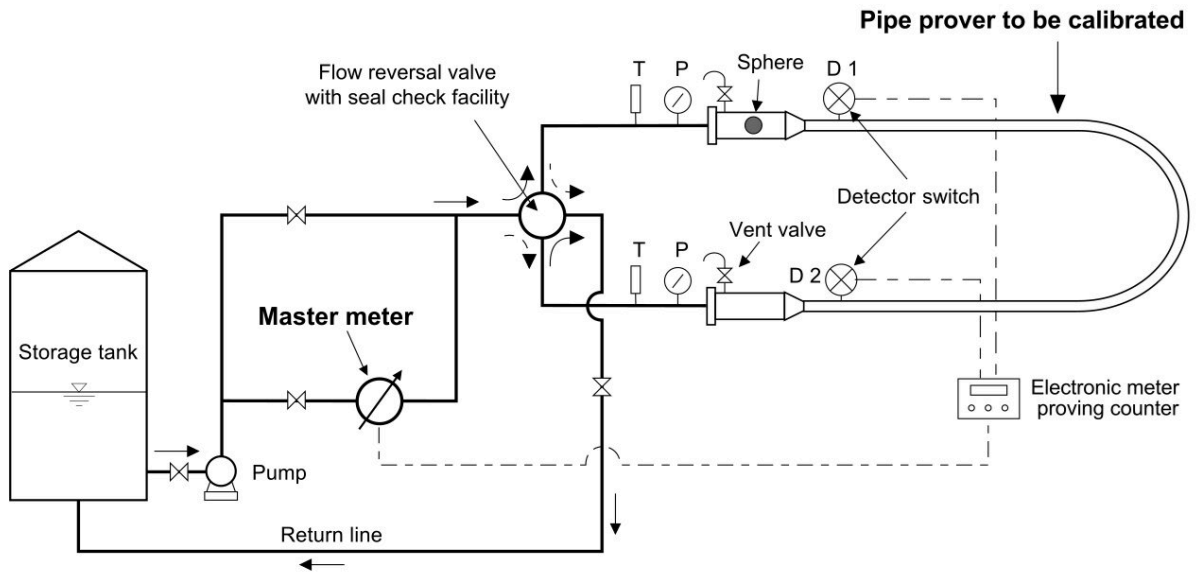

Figure A.9 — Calibration of a pipe prover (master meter method)

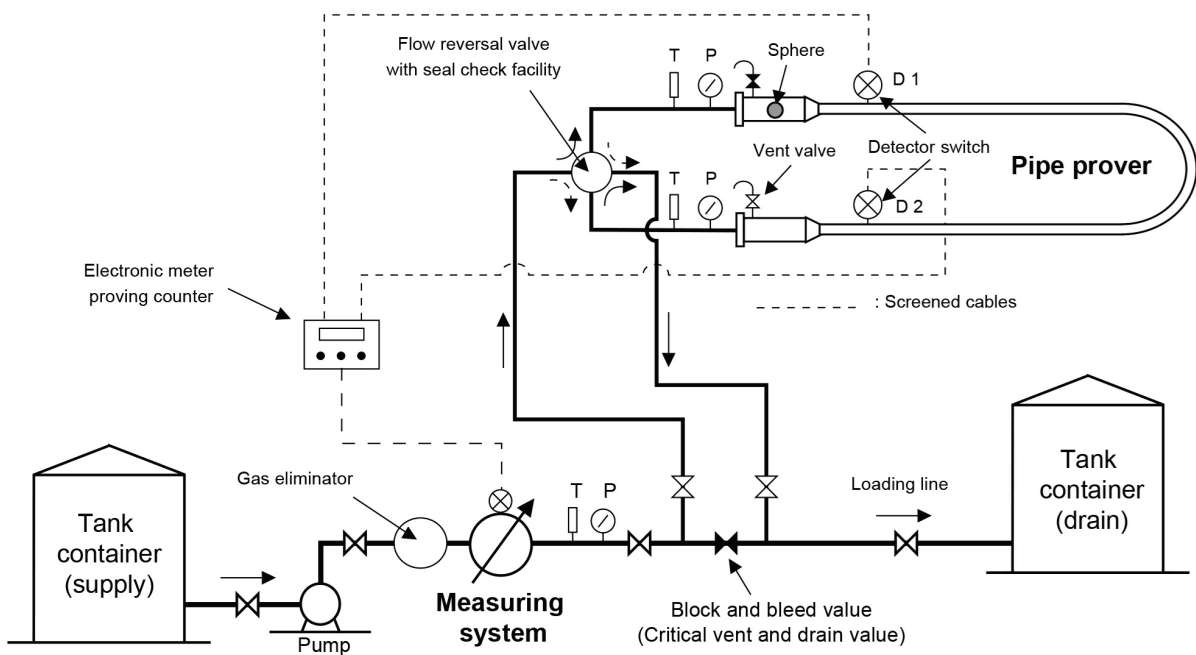

Figure A.10 — Verification of measuring systems for tank containers connected with pipelines

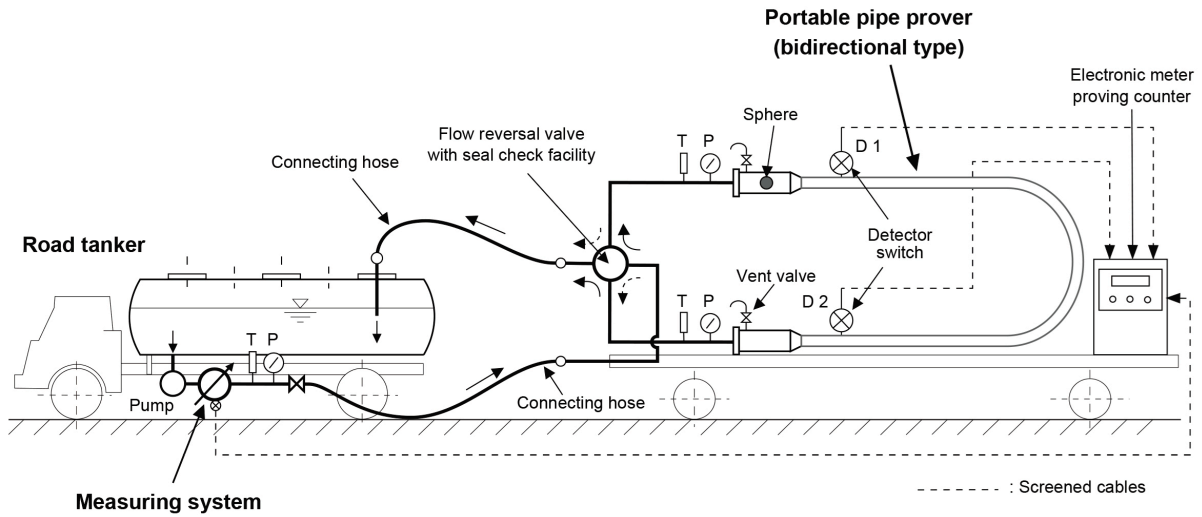

Figure A.11 — Verification of measuring systems on road tankers

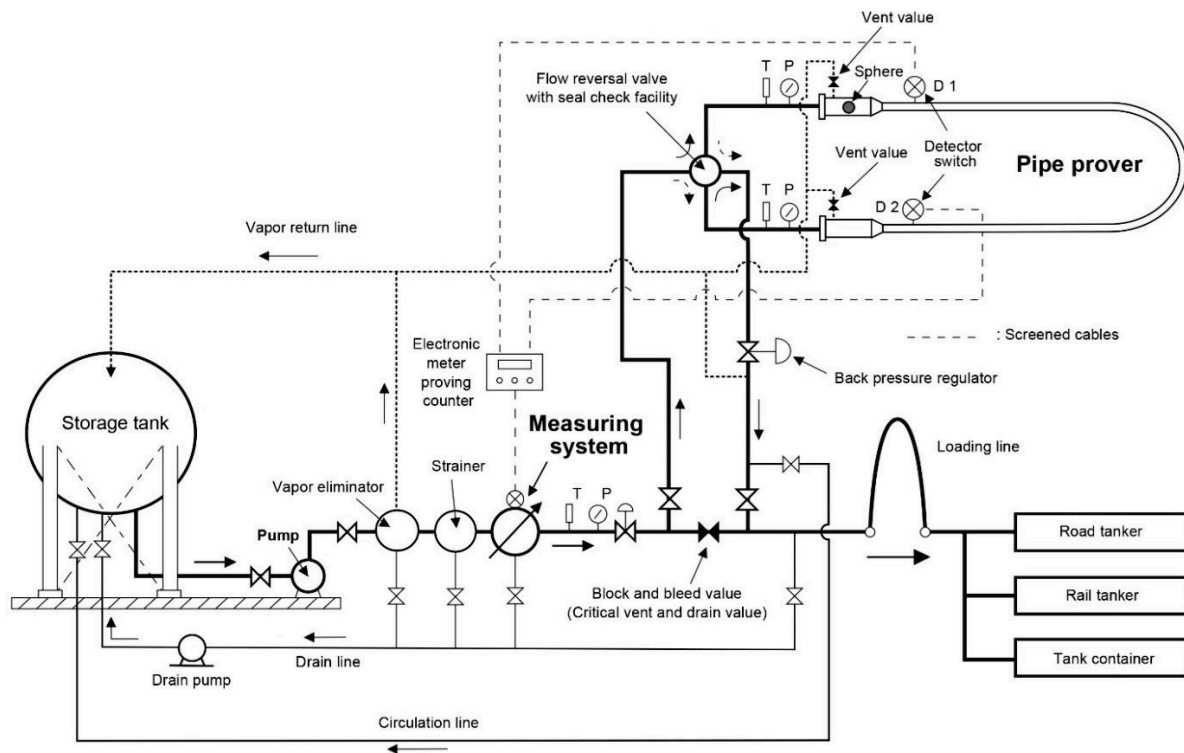

Figure A.12 — Verification of measuring systems for LPG under pressure

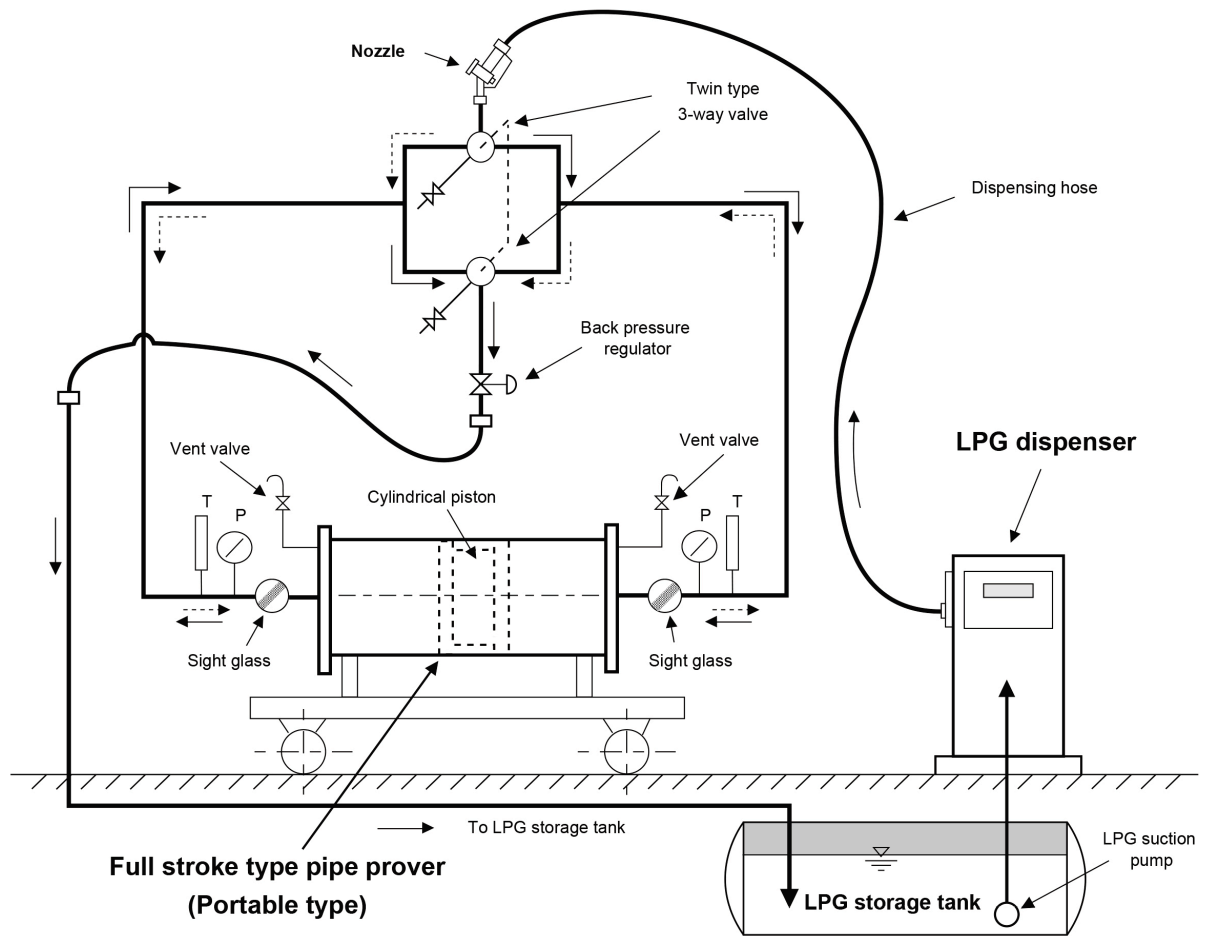

Figure A.13 — Verification of LPG dispensers

Bibliography

- [1] ISO 91:2017, *Petroleum and related products — Temperature and pressure volume correction factors (petroleum measurement tables) and standard reference conditions*
- [2] ISO 4267-2:1988, *Petroleum and liquid petroleum products — Calculation of oil quantities — Part 2: Dynamic measurement*
- [3] ISO 7278-1:1987, *Liquid hydrocarbons — Dynamic measurement — Proving systems for volumetric meters*
- [4] ISO 7278-2:1988³⁾, *Liquid hydrocarbons — Dynamic measurement — Proving systems for volumetric meters*
- [5] ISO 7278-3:1998, *Liquid hydrocarbons — Dynamic measurement — Proving systems for volumetric meters*
- [6] ISO 7278-4:1999⁴⁾, *Liquid hydrocarbons — Dynamic measurement — Proving systems for volumetric meters*
- [7] ISO 8222:2020, *Petroleum measurement systems — Calibration — Volumetric measures, proving tanks and field measures (including formulae for properties of liquids and materials)*
- [8] OIML V 1:2013, *International vocabulary of terms in legal metrology (VIML)*
- [9] OIML V 2-200:2012, *International Vocabulary of Metrology — Basic and General Concepts and Associated Terms (VIM)*, 3rd edition
- [10] OIML G 19:2017, *The role of measurement uncertainty in conformity assessment decisions in legal metrology*
- [11] OIML D 35:2020, *Petroleum measurement tables*
- [12] OIML R 49-1:2013, *Water meters for cold potable water and hot water, Part 1: Metrological and technical requirements*
- [13] OIML R 49-2:2013, *Water meters for cold potable water and hot water, Part 2: Test methods*
- [14] OIML R 49-3:2013, *Water meters for cold potable water and hot water, Part 3: Test report format*
- [15] OIML R 117-1:2019, *Dynamic measuring systems for liquids other than water, Part 1: Metrological and technical requirements*
- [16] OIML R 117-2:2019, *Dynamic measuring systems for liquids other than water, Part 2: Metrological controls and performance tests*

3) Cancelled and replaced by ISO 7278-2:2022.

4) Cancelled and replaced by ISO 7278-2:2022.

- [17] OIML R 117-3:2019, *Dynamic measuring systems for liquids other than water, Part 3: Test report format*