

INTERNATIONAL
RECOMMENDATION

OIML R 60-1

Edition 2021 (E)

Metrological regulation for load cells

Part 1: Metrological and technical requirements

Réglementation métrologique des cellules de pesée

Exigences métrologiques et techniques



Contents

Foreword		4
1 Introduction		5
2 Scope		5
3 Terminology (Terms and definitions)		7
3.1 General definitions.....		7
3.2 Categories of load cells.....		9
3.3 Construction of load cells (see sections 1 and 2.1).....		9
3.4 Metrological characteristics of a load cell.....		9
3.5 Range, capacity and output terms.....		10
3.6 Illustration of certain definitions.....		12
3.7 Measurement and error terms.....		12
3.8 Influences and reference conditions.....		15
3.9 Abbreviations.....		16
4 Description of load cells		16
5 Metrological requirements		17
5.1 Principle of load cell classification.....		17
5.2 Measuring ranges.....		19
5.3 Maximum permissible measurement errors.....		19
5.4 Repeatability error.....		20
5.5 Permissible variation of results under reference conditions.....		20
5.6 Influence quantities (Rated operating conditions).....		21
5.7 Requirements for analogue-active and digital load cells.....		22
6 Technical requirements		24
6.1 Software.....		24
6.2 Inscriptions and presentation of load cell information.....		25
Bibliography		28

Foreword

The International Organisation of Legal Metrology (OIML) is a worldwide, intergovernmental organisation whose primary aim is to harmonise the regulations and metrological controls applied by the national metrological services, or related organisations, of its Member States. The main categories of OIML publications are:

- **International Recommendations (OIML R)**, which are model regulations that establish the metrological characteristics required of certain measuring instruments and which specify methods and equipment for checking their conformity. OIML Member States shall implement these Recommendations to the greatest possible extent;
- **International Documents (OIML D)**, which are informative in nature and which are intended to harmonise and improve work in the field of legal metrology;
- **International Guides (OIML G)**, which are also informative in nature and which are intended to give guidelines for the application of certain requirements to legal metrology; and
- **International Basic Publications (OIML B)**, which define the operating rules of the various OIML structures and systems.

OIML Draft Recommendations, Documents and Guides are developed by Project Groups linked to Technical Committees or Subcommittees which comprise representatives from OIML Member States. Certain international and regional institutions also participate on a consultation basis. Cooperative agreements have been established between the OIML and certain institutions, such as ISO and the IEC, with the objective of avoiding contradictory requirements. Consequently, manufacturers and users of measuring instruments, test laboratories, etc. may simultaneously apply OIML publications and those of other institutions.

International Recommendations, Documents, Guides and Basic Publications are published in English (E) and translated into French (F) and are subject to periodic revision.

Additionally, the OIML publishes or participates in the publication of **Vocabularies (OIML V)** and periodically commissions legal metrology experts to write **Expert Reports (OIML E)**. Expert Reports are intended to provide information and advice, and are written solely from the viewpoint of their author, without the involvement of a Technical Committee or Subcommittee, nor that of the CIML. Thus, they do not necessarily represent the views of the OIML.

This publication—reference OIML R 60-1:2021—is an updated edition (developed by the OIML Certification System Management Committee) of OIML R 60-1:2017 (developed by Project Group 1 of OIML Technical Committee TC 9 *Instruments for measuring mass and density*). This updated edition consolidates the Amendment (2019-12-23) to R 60:2017, and includes other editorial and minor technical changes. It was approved for final publication by the International Committee of Legal Metrology at its 56th meeting in October 2021 and was sanctioned by the 16th International Conference on Legal Metrology in 2021. It supersedes the previous edition of R 60 dated 2017.

OIML Publications may be downloaded from the OIML web site in the form of PDF files. Additional information on OIML Publications may be obtained from the Organisation's headquarters:

Bureau International de Métrologie Légale
11, rue Turgot — 75009 Paris — France
Telephone: 33 (0)1 48 78 12 82
Fax: 33 (0)1 42 82 17 27
E-mail: biml@oiml.org
Internet: www.oiml.org

Part 1 - Metrological and technical requirements

1 Introduction

Load cells comprise a distinct element or module within other complex instruments; they do not produce distinct quantitative values that are inherently identified or associated with denominations or units. The data that can be extracted from a load cell is simply a measurement of change in the output of the load cell in relation to the input. This relative change must be converted by other elements or modules within an instrument into values that are meaningful measurements which can then be used to identify a quantity.

Although strain gauge technology was a primary focus in the initial development of R 60, it is to be understood that load cells that operate using other principles may also be evaluated under this Recommendation.

2 Scope

2.1 This Recommendation prescribes the principal metrological static requirements and static evaluation procedures for load cells used in the determination of conformity to this Recommendation. It is intended to provide authorities with uniform means for determining the metrological characteristics of load cells used in measuring instruments that are subjected to metrological controls.

It is acknowledged that test procedures found in OIML R 60-2 are useful in the evaluation of load cells that are currently in service (i.e. primarily of the strain gauge design) however, there may be variations in designs for load cells that will require additional or modified test procedures to appropriately evaluate them. These additional test procedures may be annexed when necessary.

Except where otherwise specified, these requirements apply regardless of the technology or operating principle employed. The requirements and evaluation procedures in this Recommendation have been drafted to be non-specific with regard to load cell design and their operating principles.

2.2 This Recommendation utilises the principle that several measurement errors shall be considered together when applying load cell performance characteristics to the permitted error envelope. Thus, it is not considered appropriate to specify individual errors for given characteristics (e.g. non-linearity, hysteresis, effects of influence factors), but rather to consider the total error envelope allowed for a load cell as the limiting factor. The use of an error envelope allows the balancing of the individual contributions to the total error of measurement while still achieving the intended final result.

NOTE: The error envelope may be defined as the boundary of the combined individual errors (see Table 4) as a function of the force introduced by the applied load (expressed in mass units) over the measuring range. The combined error determined may be positive or negative and include the effects of non-linearity, hysteresis and temperature.

2.3 “Weighing modules” as noted in OIML R 76 [1], T.2.2.7 (see R 60, Annex A, A.2.1), are not covered by this Recommendation. Weighing instruments that include load cells and which give an indication of mass are the subjects of separate Recommendations. While digital load cells may be covered under this Recommendation, a load cell that produces an output consisting of more than digital “raw counts” is not covered. In the illustration from OIML R 76 below, the scope of R 60 would not extend beyond module #3.

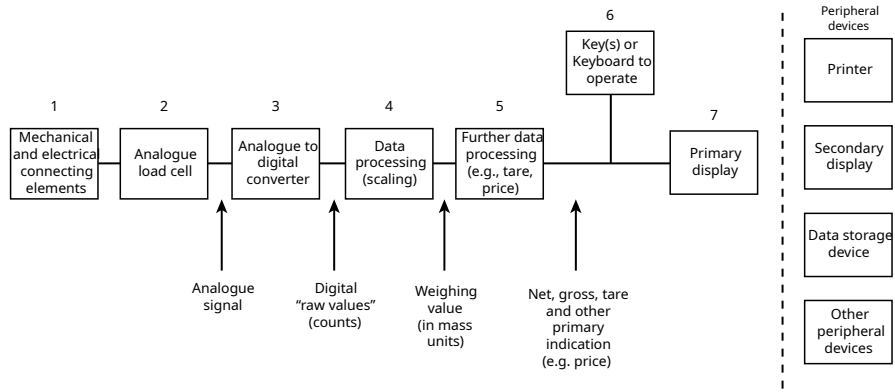

From OIML R 76:
 Definition of typical modules within a weighing system (other combinations are possible).

Figure 1 — Typical components in a weighing instrument

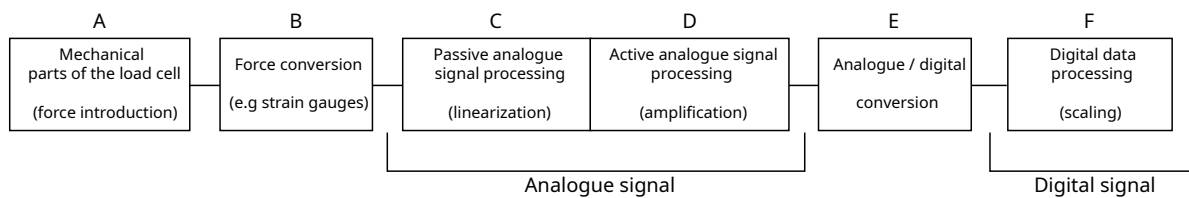

- Analogue passive load cell A - C
- Analogue active load cell A - D
- Digital load cell A - E
- Digital load cell with data processing A - F

Analogue load cells and digital load cells without data processing are within scope of OIML R 60.

Figure 2 — Characterisation of load cell capabilities

3 Terminology (Terms and definitions)

The terms most frequently used in the load cell field and their definitions are given below (see 3.6 for an illustration of certain definitions). The terminology used in this Recommendation conforms to OIML V 2-200 *International Vocabulary of Metrology—Basic and General Concepts and Associated Terms* (VIM) OIML V 2-200:2012, to OIML V 1 *International Vocabulary of Terms in Legal Metrology* (VIML) OIML V 1:2013, to OIML D 9 *Principles of metrological supervision* OIML D 9:2004, to OIML D 11 *General requirements for measuring instruments* OIML D 11:2008, and to OIML B 18 *Framework for the OIML Certification System (OIML-CS)* OIML B 18:2018.

In addition, for the purposes of this Recommendation, the following definitions apply:

3.1 General definitions

3.1.1 durability

ability of a measuring instrument to maintain its performance characteristics over a period of use

[SOURCE: OIML V 1:2013, 5.15]

3.1.2 legal metrology

practice and process of applying statutory and regulatory structure and enforcement to metrology

(For notes, refer to the OIML V 1:2013).

[SOURCE: OIML V 1:2013, 1.01]

3.1.3 load cell

measuring transducer that will produce an output in response to an applied load. This output may be converted by another device into measurement units such as mass

3.1.3.1 analogue-passive load cell

load cell from which the output provides either measurable data or direct information representing the measurand value

Note 1 to entry: The ratio between output and input may be adjustable and this type of load cell may utilise

- passive electronics (e.g. strain gauges), and
- passive temperature compensation elements

3.1.3.2 analogue-active load cell

load cell which is capable of performing the functions as described under *analogue-passive load cell* (3.1.3.1) and which also utilises active electronics

Note 1 to entry: This type of load cell may utilise the active electronics for

- gaining an electronic representation of the measurand value,

- active temperature compensation, and
- similar functions being of influence to the measurand value.

3.1.3.3 digital load cell

analogue-active load cell which includes an analogue to digital conversion device providing a representation of the measurand value in some unprocessed digital format

3.1.3.4 digital load cell equipped with further data processing (Figure 2, A-F)

analogue-active load cell which includes an analogue to digital conversion device providing a representation of the measurand value in some digital format and includes further digital processing (e.g. scaling)

3.1.4 marking

affixing of one or more marks

(For notes, refer to the OIML V 1:2013).

[SOURCE: OIML V 1:2013, 2.19]

3.1.5 metrological supervision

activity of legal metrological control to check the observance of metrology laws and regulations

(For notes, refer to the OIML V 1:2013).

[SOURCE: OIML V 1:2013, 2.03]

3.1.6 measuring transducer

device, used in measurement, that provides an output quantity having a specified relation to the input quantity

[SOURCE: OIML V 2-200:2012, 3.7]

3.1.7 performance test

test to verify whether the load cell under test is capable of performing its intended functions

3.1.8 rated operating condition

operating condition that must be fulfilled during measurement in order that a measuring instrument or measuring system perform as designed

(For notes, refer to the OIML V 2-200:2012).

[SOURCE: OIML V 2-200:2012, 4.9]

**3.1.9
sealing**

means intended to protect the measuring instrument against any unauthorised modification, readjustment, removal of parts, software, etc.

(For notes, refer to the OIML V 1:2013).

[SOURCE: OIML V 1:2013, 2.20]

**3.1.10
type (pattern) evaluation**

conformity assessment procedure on one or more specimens of an identified type (pattern) of measuring instruments which results in an evaluation report and / or an evaluation certificate

(For notes, refer to the OIML V 1:2013).

[SOURCE: OIML V 1:2013, 2.04]

**3.1.11
type approval**

decision of legal relevance, based on the review of the type evaluation report, that the type of a measuring instrument complies with the relevant statutory requirements and results in the issuance of the type approval certificate

[SOURCE: OIML V 1:2013, 2.05]

3.2 Categories of load cells**3.2.1 Application of load****3.2.1.1
compression loading**

applying a compressive force to the load receptor of a load cell

**3.2.1.2
tension loading**

applying a tension force to the load receptor of a load cell

3.3 Construction of load cells (see sections 1 and 2.1)**3.3.1
strain gauge**

analogue resistive element that is attached to a load cell structure and that changes resistance depending on the deformation of the load cell structure when compression or tension forces are applied to the load cell

3.4 Metrological characteristics of a load cell**3.4.1
humidity symbol**

symbol assigned to a load cell that indicates the conditions of humidity under which the load cell has been tested

3.4.2

load cell family

group of load cells which for the purposes of type evaluation are considered as one family and that are of:

- a) the same material or combination of materials (for example mild steel, stainless steel or aluminium);
- b) the same design of the measurement technique (for example strain gauges bonded to metal);
- c) when used, the same principle used to attach the strain gauge to the load cell;
- d) the same method of construction (for example shape, sealing of strain gauges, mounting method, manufacturing method);
- e) the same set of specifications (for example output rating, input impedance, supply voltage, cable details); and
- f) one or more load cell groups where all load cells within the group possess identical metrological characteristics (as listed in 5.1.5 — including: class; n_{LC} ; temperature rating, etc.).

Note 1 to entry: The examples provided are not intended to be limiting.

3.5 Range, capacity and output terms

3.5.1

load cell interval

subdivision of the load cell measuring range

3.5.2

load cell measuring range (for verification)

range between the maximum load of the measuring range D_{max} and minimum load of the measuring range D_{min}

load cell measuring range = $(D_{max} - D_{min})$

3.5.3

load cell output

measurable quantity into which a load cell converts the measured input quantity

3.5.4

load cell verification interval (v)

load cell interval, expressed in units of mass, used in the test of the load cell for accuracy classification

3.5.5

maximum capacity (E_{max})

largest value of a quantity expressed in units of mass, which may be applied to a load cell

3.5.6

maximum load of the measuring range (D_{max})

largest value of a quantity expressed in units of mass which can be introduced to a load cell under test

3.5.7

maximum measuring range

range of values of the quantity expressed in units of mass that may be applied to a load cell

maximum measuring range = $(E_{\max} - E_{\min})$

Note 1 to entry: maximum measuring range is the range between maximum capacity E_{\max} and minimum dead load E_{\min}

3.5.8

maximum number of load cell verification intervals (n_{LC})

maximum number of load cell verification intervals into which the maximum measuring range may be divided

3.5.9

minimum dead load (E_{\min})

smallest value of a quantity (expressed in mass units) that may be applied to a load cell

3.5.10

minimum dead load output return (DR)

difference of load cell output, expressed in units of mass at the minimum dead load (D_{\min}), measured before and after application of a load of D_{\max}

3.5.11

minimum load cell verification interval (v_{\min})

smallest load cell verification interval in units of mass into which the maximum measuring range ($E_{\max} - E_{\min}$) can be divided

3.5.12

minimum load of the measuring range (D_{\min})

smallest value of a quantity expressed in units of mass, applied to a load cell under test

3.5.13

number of load cell verification intervals (n)

total of load cell verification intervals into which the maximum measuring range is divided

3.5.14

relative minimum dead load output return (Z)

ratio of the maximum measuring range, to two times the minimum dead load output return, DR

Note 1 to entry: This ratio is used to describe multi-interval instruments.

3.5.15

relative minimum load cell verification interval (Y)

ratio of the maximum measuring range, to the minimum load cell verification interval, v_{\min}

Note 1 to entry: This ratio describes the resolution of the load cell independent from the load cell capacity.

3.5.16

safe load limit (E_{lim})

maximum load that can be applied without producing a permanent shift in the performance characteristics beyond those specified

3.5.17 warm-up time

time between the moment power is applied to a load cell and the moment at which the load cell is capable of complying with the requirements

3.6 Illustration of certain definitions

The terms that appear above the central horizontal line (related to parameters E_{\min} and E_{\max}) are parameters that are fixed by the design of the load cell. The terms that appear below that line (related to parameters D_{\min} and D_{\max}) are parameters that are variable, dependent on the conditions of the test of a load cell (in particular, those load cells used in weighing instruments).

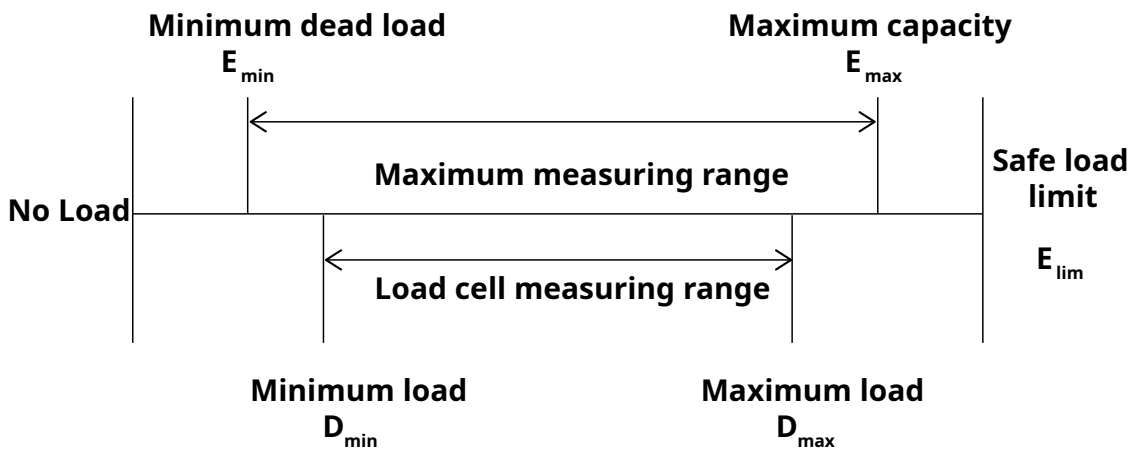

Figure 3 — Illustration of certain definitions

The following statements apply: (see also R 60-2, 2.7.3.4)

- a) $(D_{\max} - D_{\min})(E_{\max} - E_{\min})$
- b) $E_{\min} \leq D_{\min} \leq (0,1E_{\max})$, and $(0,9E_{\max}) \leq D_{\max} \leq E_{\max}$

3.7 Measurement and error terms

3.7.1 creep

change in load cell output occurring with time while under constant load and with all environmental conditions and other variables also remaining constant

3.7.2 apportioning factor (p_{LC})

value of a dimensionless fraction expressed as a decimal (for example, 0.7) representing that portion of an error observed in the (weighing) instrument which is attributed to the load cell alone

Note 1 to entry: This value is used in determining the MPE (see 3.7.10).

3.7.3 durability error

difference between the intrinsic error after a period of use and the initial intrinsic error of a measuring instrument

[SOURCE: OIML V 1:2013, 5.16]

3.7.4 expanded uncertainty

quantity defining an interval about the result of a measurement that may be expected to encompass a large fraction of the distribution of values that could reasonably be attributed to the measurand (OIML G 1-100 *Guide to the Expression of Uncertainty in Measurement*) [7]

3.7.5 fault

difference between the error of indication and the intrinsic error of a measuring instrument (For notes, refer to the OIML V 1:2013).

[SOURCE: OIML V 1:2013, 5.12]

3.7.6 fault detection output

electrical representation issued by the load cell indicating that a fault condition exists

3.7.7 hysteresis error

difference in load cell output readings for the same applied force between the reading obtained by increasing the load from minimum load (D_{\min}), and the reading obtained by decreasing the load from maximum load (D_{\max})

3.7.8 initial intrinsic error

intrinsic error of a measuring instrument as determined prior to performance tests and durability evaluations

[SOURCE: OIML V 1:2013, 5.11]

3.7.9 load cell intrinsic error

error resulting from a load cell, determined under reference conditions

3.7.10 maximum permissible error (MPE)

extreme value of measurement error, with respect to a known reference quantity value, permitted by specifications or regulations for a given measurement, measuring instrument, or measuring system

(For notes, refer to the OIML V 2-200:2012).

[SOURCE: OIML V 2-200:2012, 4.26]

**3.7.11
measurement error**

measured quantity minus a reference quantity value.

(For additional notes, refer to the OIML V 2-200:2012).

Note 1 to entry: The term “measurement error” in this Recommendation refers to load cell measurement errors.

[SOURCE: OIML V 2-200:2012, 2.16]

**3.7.12
measured quantity (value)**

quantity value representing a measurement result

(For notes, refer to the OIML V 2-200:2012).

[SOURCE: OIML V 2-200:2012, 2.10]

**3.7.13
non-linearity**

deviation from the average of the values of load cell signals from a straight line through zero force applied and maximum force applied

**3.7.14
repeatability error**

difference between load cell output readings taken from consecutive tests under the same loading and environmental conditions of measurement

**3.7.15
resolution**

smallest change in a quantity being measured that causes a perceptible change in the corresponding indication

(For notes, refer to the OIML V 2-200:2012).

[SOURCE: OIML V 2-200:2012, 4.14]

**3.7.16
significant durability error**

durability error exceeding the value specified in the applicable Recommendation

(For notes, refer to the OIML V 1:2013).

[SOURCE: OIML V 1:2013, 5.17]

**3.7.17
significant fault**

fault exceeding the applicable fault limit value

(For notes, refer to the OIML V 1:2013).

[SOURCE: OIML V 1:2013, 5.14]

3.7.18
span stability

capability of a load cell to maintain the load cell output of the load cell's measuring range over a period of use within specified limits

3.7.19
temperature effect on minimum dead load output

change of the signal output under minimum dead load due to a change in ambient temperature

3.7.20
temperature effect on sensitivity

change in sensitivity due to a change in ambient temperature

3.7.21
type approval mark

mark applied to a measuring instrument certifying its conformity to the approved type

[SOURCE: OIML V 1:2013, 3.07]

3.8 Influences and reference conditions**3.8.1**
disturbance

influence quantity having a value within the limits specified in the relevant Recommendation, but outside the specified rated operating conditions of a measuring instrument

[SOURCE: OIML V 1:2013, 5.19]

3.8.2
influence factor

influence quantity having a value which ranges within the rated operating conditions of a measuring instrument

(For notes, refer to the OIML V 1:2013).

[SOURCE: OIML V 1:2013, 5.17]

3.8.3
influence quantity

quantity that, in a direct measurement, does not affect the quantity that is actually measured, but that affects the relation between the indication and the measurement result

(For examples and notes, refer to the OIML V 2-200:2012).

[SOURCE: OIML V 2-200:2012, 2.52]

3.8.4
rated operating condition

operating condition that must be fulfilled during measurement in order that a measuring instrument or measuring system perform as designed

(For notes, refer to the OIML V 2-200:2012).

[SOURCE: OIML V 2-200:2012, 4.9]

3.8.5 reference (operating) condition

operating condition prescribed for evaluating the performance of a measuring instrument or measuring system or for comparison of measurement results

(For notes, refer to the OIML V 2-200:2012).

[SOURCE: OIML V 2-200:2012, 4.11]

3.9 Abbreviations

AC	Alternating Current
CH	Cyclic Humidity
DC	Direct Current
DR	Minimum Deadload Output Return
EMC	Electro Magnetic Compatibility
EUT	Equipment Under Test
I/O	Input/Output
IEC	International Electrotechnical Commission
ISO	International Organization for Standardization
LC	Load Cell
MPE	Maximum Permissible Error
NH	No Humidity
OIML	International Organisation of Legal Metrology
OIML R 60-1:2021 (E)	
SH	Steady-State Humidity
VIM	International Vocabulary of Metrology — Basic and General Concepts and Associated Terms
VIML	International vocabulary of terms in legal metrology

4 Description of load cells

A load cell provides an output proportional to a force resulting from applying a load. Load cells may be used as a single transducer or applied together with other load cells in a system where the design allows such application. The term “load cell” in this Recommendation is not limited to any particular type of technology or design principle.

While many technologies are used in the design of load cells, those used in legal metrology applications are commonly designed to provide an electrical output relative to a mechanical input. Both analogue and digital outputs are recognised in load cells within that category. Although strain gauge technology was a primary focus in the development of R 60, it is to be understood that load cells that operate using other principles may also be evaluated under this Recommendation. Variations of transducers that operate using alternative basis of input/output may include, but are not limited to pressure (e.g. hydraulic, pneumatic), vibratory frequency and magnetic forces.

The term load cell may describe an elemental component/module or a somewhat more complex instrument including constituents that perform functions such as signal filtering and analogue-to-digital conversion.

5 Metrological requirements

5.1 Principle of load cell classification

The classification of load cells into specific accuracy classes is provided to facilitate their application to various measuring systems. In the application of this Recommendation, it should be recognised that the effective performance of a particular load cell may be improved by compensation means within the measuring system with which it is applied. Therefore, it is not the intention of this Recommendation to require that a load cell be of the same accuracy class as the measuring system in which it may be applied. Nor does it require that a measuring instrument, indicating in units of mass for example, use a load cell which has been approved during a separate type evaluation. All data/items found in 5.1.1 to 5.1.7 shall be specified by the manufacturer.

5.1.1 Accuracy classes and their symbols

Load cells shall be ranked according to their overall performance capabilities into one of the four accuracy classes whose designations are as follows:

Class A; Class B; Class C; Class D.

5.1.2 Maximum number of load cell verification intervals

The maximum number of load cell verification intervals, n_{LC} , into which the maximum measuring range $E_{max} - E_{min}$ (see 3.5.8) can be divided in a measuring system shall be within the limits presented in Table 1.

Table 1 — Maximum number of load cell verification intervals (n_{LC}) according to accuracy class

	Class A	Class B	Class C	Class D
Lower limit	50 000	5 000	500	100
Upper limit	Unlimited	100 000	10 000	1 000

5.1.3 Minimum load cell verification interval

The minimum load cell verification interval, v_{min} , shall be specified by the manufacturer (see 3.5.11 in combination with 3.5.15).

5.1.4 Supplementary classifications

Load cells shall also be classified by the intended manner in which a load is applied to the load cell wherever there would be a risk of confusing the manner of loading (i.e. compression loading, tension loading or universal). A load cell may bear different classifications according to the intended manner in which a load is applied to the load cell. The manner of loading for which the classification(s) applies(y) shall be specified. For multiple capacity load cells, each capacity shall be classified separately.

5.1.5 Complete load cell classification

The load cell shall be classified corresponding to the following six parameters:

- a) accuracy class designation (see 5.1.1 and 6.2.4.1);
- b) maximum number of load cell verification intervals (see 5.1.2 and 6.2.4.5);

- c) intended manner of the application of the load, if necessary (see 5.1.4 and 6.2.4.2);
- d) special limits of working temperature, if applicable (see 6.2.4.3);
- e) humidity symbol, if applicable (see 6.2.4.4); and
- f) additional characterisation information, as listed below in Figure 4 , 5.1.6 and 5.1.7 .

An example illustrating the six parts of the load cell classification is shown in Figure 4.

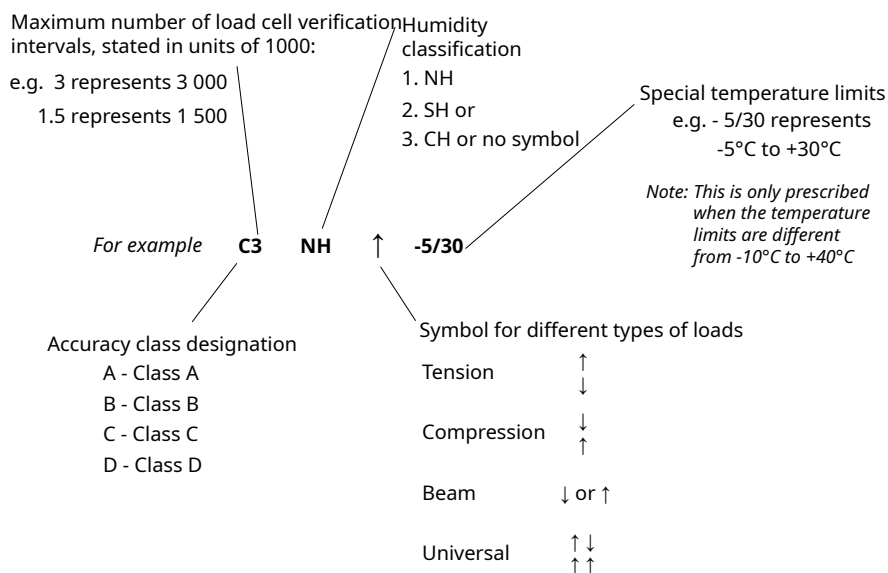

Figure 4 — Complete load cell classification

5.1.6 Standard classification

Standard classifications shall be used; examples are shown in Table 2.

Table 2 — Examples of load cell classification

Classification symbol	Description
C2	Class C, 2 000 intervals
C3 ↓ ↑ 5/35	Class C, 3 000 intervals, compression, + 5 °C to + 35 °C
C2 NH	Class C, 2 000 intervals, not to be subjected to humidity test

5.1.7 Multiple classifications

Load cells that have comprehensive classifications for the manner in which the load is applied to the load cell shall be accompanied by the relative information for each classification. An example is shown in Table 3. An illustration of the standard classification symbols, using an example, is shown in Figure 4.

Table 3 — Examples of multiple classifications

Classification symbol	Description
C2 ↑	Class C, 2 000 intervals

Table 3 (continued)

Classification symbol	Description
C1.5 ↓	Class C, 1 500 intervals
C1 ↓ ↑ — 5/30	Class C, 1 000 intervals, compression, - 5 °C to + 30 °C
C3 ↑ ↓ — 5/30	Class C, 3 000 intervals, tension, - 5 °C to + 30 °C

5.2 Measuring ranges

5.2.1 Minimum load of the measuring range (D_{\min}) (see 3.5.12)

The value of the smallest load applied to a load cell during test which is expressed in units of mass shall not be less than E_{\min} (see 3.5.9).

5.2.2 Maximum load of the measuring range (D_{\max}) (see 3.5.6)

The value of the largest load applied to a load cell during test which is expressed in units of mass shall not be greater than E_{\max} (see 3.5.5).

5.3 Maximum permissible measurement errors

Under the rated operating conditions in 5.6, the maximum permissible error (MPE) shall not exceed the values stated in 5.5.

The MPE is applicable after increasing as well as decreasing the force applied (i.e. they include hysteresis).

5.3.1 Maximum permissible errors for each accuracy class

The maximum permissible measurement errors for each accuracy class are related to the maximum number of load cell verification intervals (n_{LC}) specified for the load cell (see 5.1.2) and to the actual value of the load cell verification interval, v .

5.3.2 Type evaluation

The MPE (see 3.7.10) on type evaluation shall be the values derived using the expressions contained in the left column of Table 4. The apportioning factor, p_{LC} shall be chosen and declared (if other than 0.7) by the manufacturer and shall be in the range of 0.3 to 0.8: $(0,3 \leq p_{LC} \leq 0,8)^1$, where “m” is the value (expressed in mass) representing the force introduced by the load applied.

1) Associated with apportionment of error provisions contained within OIML R 76-1, 3.5.1 and 3.10.2.1 [1]; R 50-1, 2.2.33.2.2 [24]; R 51-1, 5.2.3.4 [25]; R 61-1, 5.2.3.3 [26]; R 106-1, 5.1.3.2 [27]; or R 107-1, 5.1.4.1 [28], when load cell is applied to such instruments.

Table 4 — Maximum Permissible Errors (MPE) on type evaluation

MPE (+/-)	Load, m			
	Class A	Class B	Class C	Class D
$p_{LC} \times 0,5v$	$0 \leq m \leq 50\,000v$	$0 \leq m \leq 5\,000v$	$0 \leq m \leq 500v$	$0 \leq m \leq 50v$
$p_{LC} \times 1,0v$	$50\,000v < m \leq 2000v$	$5\,000v < m \leq 200v$	$500v < m \leq 20v$	$50v < m \leq 200v$
$p_{LC} \times 1,5v$	$200\,000v < m$	$20\,000v < m \leq 1000v$	$2\,000v < m \leq 10\,000v$	$200v < m \leq 10v$

The value of the apportioning factor, p_{LC} shall appear on the OIML certificate, if the value is not equal to 0.7. If the apportioning factor, p_{LC} is not specified on the certificate then the value 0.7 shall be assumed. The maximum permissible error may be positive or negative and is applicable to both increasing and decreasing loads.

The limits of error shown include errors due to non-linearity, hysteresis and temperature effect on sensitivity over certain temperature ranges, specified in 5.6.1.1 and 5.6.1.2. Further errors, not included in the Table 4 limits of error, are treated separately.

5.4 Repeatability error

The maximum difference between the results of five identical load applications for classes A and B and of three identical load applications for classes C and D shall not be greater than the absolute value of the MPE for that load.

5.5 Permissible variation of results under reference conditions

5.5.1 Creep

The difference between the reading taken upon the application of a maximum load (D_{max}) and the reading observed within and after 30 minutes of exposure of 90 % to 100 % of E_{max} shall not exceed 0.7 times the absolute value of MPE for the applied load.

Regardless of any value declared by the manufacturer for the apportioning factor, p_{LC} , the MPE for creep shall be determined from $tab \leq -4$ using the apportioning factor, $p_{LC} = 0,7$.

The difference in readings taken after 20 minutes of exposure to 90 % to 100 % of E_{max} and at 30 minutes of exposure to 90 % to 100 % of E_{max} shall not exceed 0.15 times the absolute value of MPE.

EXAMPLE:

Load cell class: C3 (declared by the manufacturer)

Apportioning factor: $p_{LC} = 0,7$

Applied load: $D_{max} = E_{max}$ (test specification)

Maximum difference between the reading = $0,7 \times (0,7 \times 1,5v) = 0,735v$

EXAMPLE:

Load cell class: C3 (declared by the manufacturer)

Apportioning factor: $p_{LC} = 0,7$

Applied load: $D_{max} = E_{max}$ (test specification)

Maximum difference between the initial reading = $0,15 \times (0,7 \times 1,5 v) = 0,1575 v$

5.5.2 Minimum dead load output return (DR) (see 3.5.10)

The difference between the initial reading of the minimum load output (D_{\min}) and the reading of D_{\min} at the conclusion of the creep test (5.5.1), shall not exceed half the value of the load cell verification interval ($0,5 v$).

NOTE: It should be noted that DR is the minimum dead load output return expressed in mass units (g, kg, t). DR has to be adjusted in a value expressed in load cell verification intervals, v .

5.6 Influence quantities (Rated operating conditions)

Load cells shall be evaluated under the conditions specified in 5.6.1 to 5.6.3. An evaluation may include additional special testing performed under conditions that vary from those specified in 5.6.1 to 5.6.3 if requested and specified by the applicant submitting the load cell for evaluation. This special testing may be performed in addition to, but not instead of testing under the specified conditions in 5.6.1 to 5.6.3.

Load cells that are equipped with functions typically performed by complete instruments may be required to be evaluated against additional requirements contained in other OIML Recommendations for those complete instruments. These additional evaluations are outside the scope of this Recommendation (see 2.3 and Figure 2).

5.6.1 Temperature

5.6.1.1 Temperature limits

Excluding temperature effects on minimum dead load output, the load cell shall perform within the limits of error in 5.3.2 over the temperature range of -10 °C to $+40\text{ °C}$, unless otherwise specified as in 5.6.1.2.

NOTE: National legislation may prescribe alternative temperature limits outside of the range specified above as appropriate for local climatic conditions and the environmental conditions that can be anticipated.

5.6.1.2 Special limits

Load cells for which particular limits of working temperature are specified shall satisfy, within those ranges, the conditions defined in 5.3.2. The span of these ranges shall be at least:

- 5 °C for load cells of class A;
- 15 °C for load cells of class B;
- 30 °C for load cells of classes C and D.

5.6.1.3 Temperature effect on minimum dead load output

The minimum dead load output of the load cell over the temperature range, as specified in 5.6.1.1 or 5.6.1.2, shall not vary by an amount greater than the apportioning factor, p_{LC} , times the minimum load cell verification interval, v_{\min} , for any change in ambient temperature of:

- 2 °C for load cells of class A;
- 5 °C for load cells of class B, C and D.

5.6.2 Barometric pressure

The output of the load cell shall not vary by an amount greater than the minimum load cell verification interval, v_{\min} , for any incremental change in barometric pressure equivalent to 1 kPa.

5.6.3 Humidity

With respect to humidity conditions, this Recommendation defines 3 humidity classes: CH (cyclic humidity — as standard), NH (no humidity), and SH (steady-state humidity). In the case of class NH or SH, the class designation shall be marked on the load cell. In the case of class CH, class designation marking of the load cell is not mandatory.

5.6.3.1 Humidity error — CH or unmarked load cells

This requirement is only applicable to load cells marked CH or with no humidity symbol marking and not applicable to load cells marked NH or SH.

The influence of exposure to temperature cycles specified in R 60-2, 2.10.5.12 OIML R 60-2, 2.10.5.12 on the load cell output for minimum load shall not be greater than 4 % of the difference between the output on the maximum capacity, E_{\max} , and that at the minimum dead load, E_{\min} .

The influence of exposure to temperature cycles specified in R 60-2, 2.10.5.12 on the load cell output for the maximum load shall not be greater than the load cell verification interval, v .

5.6.3.2 Humidity error — SH marked load cells

This requirement is only applicable to load cells marked SH and is not applicable to load cells marked NH or CH or with no humidity symbol marking.

A load cell shall meet the MPE applicable to the load applied as specified in Table 4, when exposed to conditions of relative humidity variations as specified in R 60-2, 2.10.6.11.

5.7 Requirements for analogue-active and digital load cells

5.7.1 General requirements

In addition to the other requirements of this Recommendation, analogue-active load cells shall comply with the following requirements. The MPE shall be determined using an apportioning factor, p_{LC} greater than or equal to 0.7 and less than or equal to 0.8 ($0,7 \leq p_{LC} \leq 0,8$) substituted for the apportioning factor, p_{LC} , that is declared by the manufacturer and applied to the other requirements.

If a digital load cell equipped with further data processing (3.1.3.4) is configured with substantial additional electronic functions (e.g. display of indications, frequency counter) that are typical of an electronic weighing instrument, it may be considered outside the scope of this Recommendation and the load cell may need to undergo additional evaluation against requirements contained in other OIML Recommendations which are applicable to weighing instruments.

5.7.1.1 Faults

An analogue-active load cell shall be designed and manufactured such that when it is exposed to electrical disturbances either:

- a) significant faults do not occur; or
- b) significant faults are detected and acted upon.

If significant faults do occur, and the load cell is equipped with the intelligence to detect and act upon significant faults through the instrument that the load cell is installed in, the reporting of and acting upon significant faults would then be evaluated under the appropriate Recommendation for the complete instrument.

Messages of significant faults should not be confused with other messages presented.

NOTE: A fault in value that is equal to or smaller than the load cell minimum verification interval, v_{\min} , is allowed.

5.7.1.2 Acting upon significant faults

When a significant fault has been detected, either the load cell shall be made inoperative automatically or a fault detection output shall be issued automatically. This fault detection output shall continue until the fault has been resolved.

5.7.1.3 Durability

The load cell shall be suitably durable so that the requirements of this Recommendation may be met in accordance with the intended use of the load cell.

5.7.1.4 Compliance with requirements

An analogue-active load cell is presumed to comply with the requirements in 5.7.1.1 and 5.7.1.3, if it passes the examinations specified in 5.7.2 and R 60-2, 2.10.7.

5.7.1.5 Application of the requirements in 5.7.1.1

The requirements in 5.7.1.1 may be applied separately to each individual cause or significant fault. The choice of whether 5.7.1.1 a) or 5.7.1.1 b) is applied is left to the manufacturer.

5.7.2 Influence quantities

5.7.2.1 Warm-up time

During the designed warm-up time of an analogue-active load cell there shall be no transmission of measurement results.

5.7.2.2 Mains power supply (AC)

An analogue-active load cell that operates from a mains power supply shall be designed to comply with the metrological requirements if the mains power supply varies in voltage from -15 % to +10 % of the supply voltage.

5.7.2.3 Battery power supply (DC)

An analogue-active load cell that operates from a battery power supply shall either continue to function correctly, or not provide a measurement result whenever the voltage is below the value specified by the manufacturer.

5.7.2.4 Maximum allowable variations during voltage variations

All functions shall operate as designed.

All measurement results shall be within maximum permissible errors.

5.7.2.5 Disturbances

When an analogue-active load cell is subjected to the disturbances specified in R 60-2, 2.10.7.5 to 2.10.7.10 (also summarised in Table 5), the difference between the load cell output due to a disturbance and the load cell output without disturbance (fault) shall satisfy the conditions in 5.7.1.1.

Table 5 — Influence factors and disturbances

Test	Subclause R 60-2, 2.10 test procedure	p_{LC}^a	Characteristic under test
Warm-up time	2.10.7.3	1.0	Influence factor
Power voltage variations	2.10.7.4		Influence factor
Short-time power reductions	2.10.7.5		Disturbance
Bursts (electrical fast transients)	2.10.7.6		Disturbance
Surge	2.10.7.7		Disturbance
Electrostatic discharge	2.10.7.8		Disturbance
Electromagnetic susceptibility	2.10.7.9		Disturbance
Immunity to conducted electromagnetic fields	2.10.7.10		Disturbance
Span stability	2.10.7.11		Influence factor

^a $p_{LC} = 0,7$ shall be used for analogue-active load cells during influence factors tests.

5.7.2.6 Span stability: maximum allowable variation requirements (not applicable to class A load cells)

When an analogue-active load cell is subjected to the span stability test specified in R 60-2, 2.10.7.11, the variation in the load cell span measurement results shall not exceed the greater of: half the load cell verification interval; or half the absolute value of the MPE for the applied test load D_{max} .

6 Technical requirements

6.1 Software

Provision shall be made for appropriate sealing by mechanical, electronic and/or cryptographic means, making any change that affects the metrological integrity of the device impossible or evident. Any embedded programming (i.e. firmware) that influences the raw count output of the load cell will be evaluated under the terms of this Recommendation. In addition, if the software modifies load cell performance, not exceeding the functions of analogue to digital conversion and the linearization of the load cell output, then that software shall be evaluated under the terms in this Recommendation and in accordance with OIML D 31 [8]. Any weighing instrument function shall be evaluated under other appropriate Recommendations for weighing instruments.

Functionality of any software which is not covered by this Recommendation, e.g. functionalities of weighing instruments, is outside the scope of this Recommendation and is therefore not evaluated. It may be required to undergo additional evaluations against other requirements contained in the applicable OIML Recommendations for weighing instruments.

The requirements which are relevant to the evaluation of load cells and provided in OIML D 31 [8] shall be fulfilled for the load cell by taking into account the following aspects.

- a) In general, for load cells, the severity level I, examined with validation procedure A, is required.
- b) For legally relevant software of digital load cells the following statements according to OIML D 31 [8] shall be applied.
 - 1) The exception described in OIML D 31, 5.1.1 [8] for an imprint of the software identification is allowed.
 - 2) The level of conformity of manufactured devices to the approved type is according to OIML D 31, 5.2.5 (subclause a) [8].
 - 3) Updating the legally relevant software of a load cell in the field is possible via verified or traced update according to OIML D 31, 5.2.6.2 and 5.2.6.3 [8].
 - 4) The software documentation shall include descriptions according to the applicable requirements of OIML D 31, 6.1.1 [8].

The validation procedures are described in OIML D 31, 6.4 [8].

6.2 Inscriptions and presentation of load cell information

Technical information markings including load cell classifications as indicated in 5.1.5 must be specified for the load cell(s).

6.2.1 Mandatory markings on the load cell

The following mandatory markings shall be clearly and indelibly marked on the load cell. When a sticker or data plate is used it shall be impossible to remove them without damaging them.

- a) Manufacturer's name or trade mark
- b) Manufacturer's type designation or load cell model
- c) Serial number
- d) Maximum capacity as: E_{\max} = (in units g, kg, t)
- e) Year of production
- f) Type approval mark (if applicable)

If due to the limitation of the size of the load cell, it is impossible to apply all the mandatory markings, the manufacturer's name or trade mark, the load cell type designation, the serial number, and the maximum capacity shall be provided as a minimum on the load cell itself. All other mandatory information shall be provided in an accompanying document supplied by the manufacturer and submitted to the user. Where such a document is provided, the information required in 6.2.2 shall also be given therein.

6.2.2 Mandatory additional information

The following mandatory information shall be provided in a document accompanying the load cell supplied by the manufacturer and submitted to the user or, if space permits, they may be marked on the load cell. Where the information provided is associated with a specific unit of measure, the unit (g, kg, t) shall also be specified.

- a) Manufacturer's name or trade mark

- b) Manufacturer's type designation or load cell model
- c) Accuracy class(es); see 6.2.4.1
- d) Type of load; see 6.2.4.2
- e) Working temperature when required; see 6.2.4.3
- f) Humidity symbol when required; see 6.2.4.4
- g) Maximum capacity as: $E_{\max} =$
- h) Minimum dead load as: $E_{\min} =$
- i) Safe load limit as: $E_{\lim} =$
- j) Minimum load cell verification interval as v_{\min} (or relative minimum load cell verification interval, Y) =
- k) Value of the apportioning factor, p_{LC} , if not equal to 0.7; and
- l) Other pertinent conditions that must be observed to obtain the specified performance (for example, electrical characteristics of the load cell such as output rating, input impedance, supply voltage, cable details, mounting torque, etc.).

6.2.3 Non-mandatory additional information

In addition to the information required in 6.2.2, the following information may optionally be specified:

- a) for a weighing instrument (for example a multiple range instrument according to OIML R 76 [1]), the relative v_{\min} , Y , where $Y = (E_{\max} - E_{\min}) / v_{\min}$ (see 3.5.15);
- b) for a weighing instrument (for example a multi-interval instrument according to OIML R 76) [1], the relative DR, Z , where $Z = (E_{\max} - E_{\min}) / (2 \times DR)$ (see 3.5.14) and the value of DR (see 3.5.10) is set at the maximum permissible minimum dead load output return according to R 60-2, 2.10.1;
- c) other information considered necessary or useful by the manufacturer.

6.2.4 Specific markings

6.2.4.1 Accuracy class designation

Class A load cells shall be designated by the character "A", class B by "B", class C by "C" and class D by the character "D".

6.2.4.2 Designation of the type of load applied to the load cell

The designation of the type of load applied to the load cell shall be specified when it is not clearly apparent from the load cell construction, using the symbols shown in Table 6.

Table 6 — Symbols for different types of load transmission principles

Tension	↑ ↓
Compression	↓ ↑
Beam	↑ or ↓
Universal	↑ ↓

Table 6 (continued)

| ↓ ↑

6.2.4.3 Working temperature designation

The special limits of working temperature, as referred to in 5.6.1.2, shall be specified when the load cell cannot perform within the limits of error in 5.3 to 5.6 over the temperature range specified in 5.6.1.1. In such cases, the limits of temperature shall be designated in degrees Celsius (°C).

6.2.4.4 Humidity symbols

- a) A load cell not designed to meet performance criteria evaluated under R 60-2, 2.10.5 or 2.10.6 shall be marked by the symbol NH.
- b) A load cell submitted for evaluation and designed to meet performance criteria evaluated under R 60-2, 2.10.5 shall be marked by the symbol CH or not be marked with any humidity classification.
- c) A load cell submitted for evaluation and manufactured to meet performance criteria evaluated under R 60-2, 2.10.6 shall be marked by the symbol SH.

6.2.4.5 Maximum number of load cell verification intervals

The maximum number of load cell verification intervals for which the accuracy class applies shall be designated in actual units (e.g. 3 000) or, when combined with the accuracy class designation (see 6.2.4.1) to produce a classification symbol (see 5.1.6), it shall be designated in units of 1 000.

Bibliography

- [1] OIML V 1:2013, *International Vocabulary of Terms in Legal Metrology (VIML)*
- [2] OIML V 2-200:2012, *International Vocabulary of Metrology — Basic and General Concepts and Associated Terms (VIM)*
- [3] OIML D 9:2004, *Principles of metrological supervision*
- [4] OIML D 11:2008, *General requirements for electronic measuring instruments*
- [5] OIML B 18:2018, *Framework for the OIML Certification System (OIML-CS)*

INTERNATIONAL
RECOMMENDATION

OIML R 60-2

Edition 2021 (E)

Metrological regulation for load cells

Part 2: Metrological controls and performance tests

Réglementation métrologique des cellules de pesée

Contrôles métrologiques et essais de performance



Contents

Foreword	32
1 Metrological controls	33
1.1 Liability to legal metrological controls.....	33
1.2 Measurement standards.....	33
2 Type evaluation	33
2.1 Scope.....	33
2.2 Test requirements.....	33
2.3 Selection of specimens for evaluation.....	33
2.4 Selection of load cells within a family.....	34
2.5 Documentation.....	36
2.6 Examinations.....	37
2.7 Performance tests.....	37
2.8 Rules concerning the determination of errors.....	39
2.9 Variation of results under reference conditions.....	40
2.10 Test procedures.....	41
2.11 Test sequence.....	56
2.12 OIML certificate.....	57

Foreword

The International Organisation of Legal Metrology (OIML) is a worldwide, intergovernmental organisation whose primary aim is to harmonise the regulations and metrological controls applied by the national metrological services, or related organisations, of its Member States. The main categories of OIML publications are:

- **International Recommendations (OIML R)**, which are model regulations that establish the metrological characteristics required of certain measuring instruments and which specify methods and equipment for checking their conformity. OIML Member States shall implement these Recommendations to the greatest possible extent;
- **International Documents (OIML D)**, which are informative in nature and which are intended to harmonise and improve work in the field of legal metrology;
- **International Guides (OIML G)**, which are also informative in nature and which are intended to give guidelines for the application of certain requirements to legal metrology;
- **International Basic Publications (OIML B)**, which define the operating rules of the various OIML structures and systems; and

OIML Draft Recommendations, Documents and Guides are developed by Project Groups linked to Technical Committees or Subcommittees which comprise representatives from OIML Member States. Certain international and regional institutions also participate on a consultation basis. Cooperative agreements have been established between the OIML and certain institutions, such as ISO and the IEC, with the objective of avoiding contradictory requirements. Consequently, manufacturers and users of measuring instruments, test laboratories, etc. may simultaneously apply OIML publications and those of other institutions.

International Recommendations, Documents, Guides and Basic Publications are published in English (E) and translated into French (F) and are subject to periodic revision.

Additionally, the OIML publishes or participates in the publication of **Vocabularies (OIML V)** and periodically commissions legal metrology experts to write **Expert Reports (OIML E)**. Expert Reports are intended to provide information and advice, and are written solely from the viewpoint of their author, without the involvement of a Technical Committee or Subcommittee, nor that of the CIML. Thus, they do not necessarily represent the views of the OIML.

This publication—reference OIML R 60-2:2021—is an updated edition (developed by the OIML Certification System Management Committee) of R 60-2:2017 (developed by Project Group 1 of OIML Technical Committee TC 9 *Instruments for measuring mass and density*). This updated edition consolidates the Amendment (2019-12-23) to R 60:2017, and includes other editorial and minor technical changes. It was approved for final publication by the International Committee of Legal Metrology at its 56th meeting in October 2021 and was sanctioned by the 16th International Conference on Legal Metrology in 2021. It supersedes the previous edition of R 60 dated 2017.

OIML Publications may be downloaded from the OIML web site in the form of PDF files. Additional information on OIML Publications may be obtained from the Organisation's headquarters:

Bureau International de Métrologie Légale
11, rue Turgot — 75009 Paris – France
Telephone: 33 (0)1 48 78 12 82
Fax: 33 (0)1 42 82 17 27
E-mail: biml@oiml.org
Internet: www.oiml.org

Part 2 - Metrological controls and performance tests

1 Metrological controls

1.1 Liability to legal metrological controls

1.1.1 Imposition of controls

This Recommendation prescribes performance requirements for load cells used in devices or systems subjected to legal metrological control. National legislation may impose metrological controls that verify compliance with this Recommendation. Such controls, when imposed, may include type evaluation.

1.2 Measurement standards

The expanded uncertainty, U (for coverage factor $k = 2$), for the combination of the force-generating system and the indicating instrument used during the tests to observe the load cell output shall be less than 1/3 times the MPE of the load cell under test [OIML G 1-100 *Guide to the Expression of Uncertainty in Measurement*] [7].

2 Type evaluation

2.1 Scope

This section provides test procedures for type evaluation testing of load cells.

Wherever possible, test procedures have been established to apply as broadly as possible to all load cells within the scope of OIML R 60.

The procedures apply to the testing of load cells only. No attempt has been made to cover testing of complete systems that include load cells.

2.2 Test requirements

Test procedures for the type evaluation of load cells are provided in 2.10 and the Test Report Format is provided in OIML R 60-3. Initial and subsequent verification of load cells independent of the measuring system in which they are used is normally considered inappropriate if the complete system performance is verified by other means.

2.3 Selection of specimens for evaluation

Type evaluation shall be carried out on at least one specimen, which represents the type. The evaluation shall consist of the examination and tests specified in 2.10.

In case the applicant wants to have several versions or measuring ranges approved, the issuing authority decides which version(s) and range(s) shall be supplied.

If a specimen does not pass a specific test as a result of the design of the type and therefore has to be modified, the applicant shall carry out this modification to all the specimens supplied for test. If the modification has been applied to all sub-types of the family which have the common design defect that required modification, it is then required that the other specimens that have been submitted shall be re-tested. Depending on the modification this may involve a repeat of the specific test or a complete re-test.

If during the evaluation the specimen experiences malfunction or breakage that necessitates a repair in order to complete the test, the applicant shall verify whether this repair concerns an incident or whether a modification will need be made to the design. In the latter case the modification shall be applied to all specimens supplied for the test and the applicable documentation shall be updated accordingly.

If the issuing authority has reason to believe that a modification or repair could cause a different outcome for test result(s) than the result(s) which was observed prior to any modification, these tests shall be repeated. The reason for repeating a test shall be given within the scope of the test report.

2.3.1 Number of load cells to be tested

The selection of load cells to be tested shall be such that the number of load cells to be tested is minimised (see practical example in Annex D).

2.4 Selection of load cells within a family

In order to accelerate the test procedure, the test laboratory may carry out different tests simultaneously on different units. In this case, the issuing authority decides which version or measuring range will be subjected to a specific test.

All accuracy and influence tests, including a span stability test for digital load cells, shall be performed on the same unit. Disturbance tests on digital load cells may be (simultaneously) carried out on not more than two additional load cells.

Where a family composed of one or more groups of load cells of various capacities and characteristics is presented for type evaluation, the following provisions shall apply.

When classifying load cells on the basis of the shape design, additional consideration should be given to design criteria such as the geometrical characteristics of the areas of the load cell created during fabrication. Examples of strain gauge-type load cells with identical outer dimensions but different geometries are shown below.

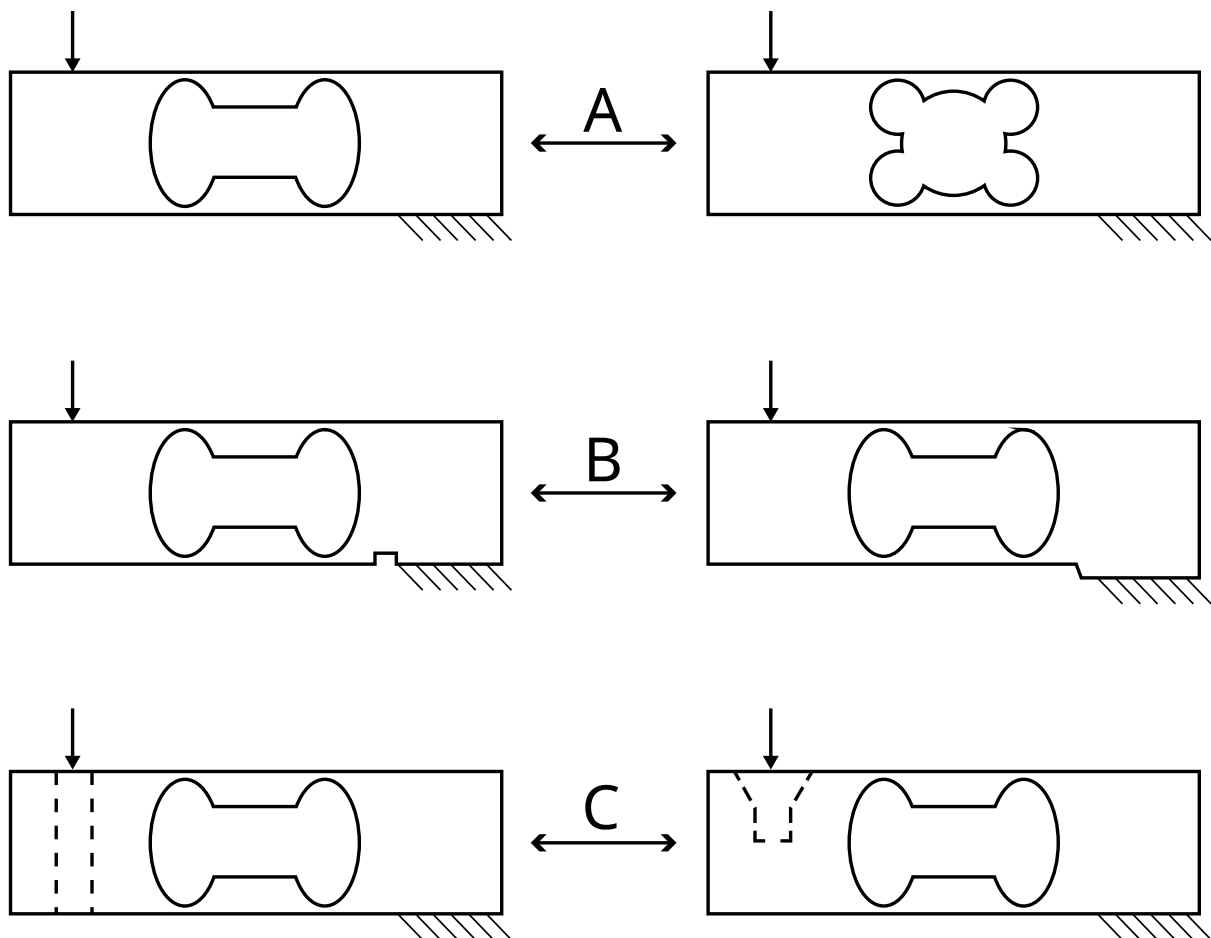

Key

- A difference of geometry in the area of thin places (i.e. round or oval drilling)
- B difference of geometry in the area of fixing/load introduction (i.e. groove, base, offset)
- C difference of geometry in the inner of fixing/load introduction (i.e. drilling, thread, dropping)

Figure 1 — Examples of strain gauge-type load cell design shapes

2.4.1 Load cells of the same capacity belonging to different groups

Where load cells of the same family and same capacity belong to different groups, the selection of a load cell for testing requires a choice between characteristics of the load cells. In this case, the load cell requiring the most onerous tests shall be selected. This selection will result in the load cell with the most stringent metrological characteristics being tested.

2.4.2 Load cells with a capacity in between the capacities tested

Load cells of the same family with a capacity in between the capacities tested, as well as those above the largest capacity tested, but not over 5 times the largest capacity tested, may be included in the certificate and are deemed to fulfil the requirements of this Recommendation. This is under the provision that along with the change of capacity there is no change of measurement principle or material used in the construction of the load cell (e.g. from bending beam to shear beam or stainless steel replacing aluminium).

2.4.3 Smallest capacity load cell from the group

For any family, the smallest capacity load cell from the group with the best characteristics shall be selected for testing. For any group, the smallest capacity load cell in the group shall always be selected for test unless that capacity falls within the range of allowed capacities of selected load cells having better metrological characteristics according to the requirements of 2.4.1 and 2.4.2 .

2.4.4 Ratio of largest capacity to the nearest smaller capacity

When the ratio of the largest capacity load cell in each group to the nearest smaller capacity having been selected for test is greater than 5, then another load cell shall be selected. The selected load cell shall have a capacity between 5 and 10 times that of the nearest smaller capacity load cell which has been selected. When no capacity meets this criterion, the selected load cell shall be that having the smallest capacity exceeding 10 times that of the nearest smaller capacity load cell which has been selected.

2.4.5 Humidity test

If more than one load cell of a family has been submitted for testing, only one load cell shall be tested for humidity when applicable.

2.4.6 Selection of analogue-active and digital load cells

For analogue-active load cells (R 60-1, 3.1.3.2) with active electronics that do not differ between load cells and family and for digital load cells (R 60-1, 3.1.3.3) with an additional digital converter that does not differ between load cells and family all applicable tests shall be performed on the load cell with the minimum, $\mu V/v_{min}$ as input for the analogue to digital converter (same principle as OIML R 76 *Non-automatic weighing instruments* [1], Annex C, Table 12).

Notwithstanding this requirement, the criteria for assignment of a load cell to a family and the selection of test specimens found in 2.4.1 to 2.4.5 shall be observed.

2.5 Documentation

The documentation submitted with the application for type evaluation shall include:

- a) a description of its general principle of measurement;
- b) mechanical drawings (including documents on the load transmission(s) as per Annex E);
- c) electric/electronic diagrams;
- d) installation requirements (physical and electrical) if appropriate;
- e) operating instructions that shall be provided to the user if appropriate;
- f) documents or other evidence to support and demonstrate the manufacturer's belief that the design and characteristics of the load cell will comply with the requirements of this Recommendation; and
- g) documentation relative to software if appropriate.

If the test laboratory deems this necessary, it can require more detailed documentation; either to be able to study the quality of the instrument, or to be able to fully define the approved type, or both.

If the manufacturer does not prescribe a specific load transmission, it will be the responsibility of the test laboratory to decide what kind of load transmission is to be used for testing (also see Annex E).

2.6 Examinations

Examinations and testing of load cells are intended to verify compliance with the requirements of R 60-1.

The load cell shall be given a visual inspection to obtain a general appraisal of its design and construction and the documentation shall be studied.

In particular, the following aspects shall be examined:

- a) accuracy classes and their symbols (R 60-1, 5.1.1 and 6.2.4.1);
- b) maximum number of load cell verification intervals (R 60-1, 5.1.2 and 6.2.4.5);
- c) load cell measuring ranges (R 60-1, 3.5.2);
- d) apportioning of errors (R 60-1, 5.3.2 and 3.7.2);
- e) construction of load cells (R 60-1, 3.3);
- f) software (R 60-1, 6.1) (if applicable);
- g) inscriptions and presentation of load cell information (R 60-1, 6.2); and
- h) installation instructions/recommendations.

2.7 Performance tests

2.7.1 Purpose

The following test procedures for the quantitative determination of load cell performance characteristics are established to ensure uniform type evaluation.

2.7.2 Test equipment

The basic equipment for type evaluation tests consists of a force-generating system and a suitable indicating instrument, which measures the output of the load cell (see 1.2).

2.7.3 General considerations for environmental and test conditions

2.7.3.1 Environmental conditions

Tests shall be performed under stable environmental conditions. The ambient temperature is deemed to be stable when the difference between extreme temperatures noted during the test does not exceed one fifth of the temperature range of the load cell under test, without being greater than 2 °C.

Conditions involving electrical power supplies, electromagnetic fields and radio frequency fields are to be measured/controlled when the load cell is being evaluated against the effects of these influences, and must also be considered when there is a potential for these types of conditions to impart effects on other tests.

2.7.3.2 Acceleration of gravity

The mass standards used to generate the force applied during testing shall be corrected, if necessary, for the site of testing and the value of the gravity constant, g , at the test site shall be recorded with the test results. The value of the mass standards used to generate the force shall be traceable to the appropriate national or international standard of mass.

2.7.3.3 Loading conditions

Particular attention shall be paid to loading conditions to prevent the introduction of errors not inherent to the load cell. Factors such as surface roughness, flatness, corrosion, scratches, eccentricity, etc., should be taken into consideration. Loading conditions shall be in accordance with the specifications of the load cell manufacturer. The loads shall be applied and removed along the sensitive axis of the load cell without introducing shock to the load cell.

Since the aim of this test is not to measure the influence on the metrological performances of mounting/dismounting the load cell on/from the force-generating system, the installation of the load cell in the force-generating system shall be done with particular care. In addition, the installation shall be done with consideration given to the intended use of the load cell and the load transmission. The effect on the metrological performance caused by mounting/dismounting the load cell on/from the force-generating system should be negligible in order to establish the magnitude of the test parameter. If possible, the load cell should not be dismantled from the force-generation system during the entire period of the test.

2.7.3.4 Measuring range limits

With consideration given to the capability of the force-generating system, the minimum load, D_{\min} , shall be as near as possible to but not less than the minimum dead load, E_{\min} , and shall not be higher than a value equal to 10 % of E_{\max} . The maximum load, D_{\max} , shall be not less than 90 % of E_{\max} , nor shall it be greater than E_{\max} (refer to R 60-1, Figure 3).

2.7.3.5 Reference standards

All standards and measuring instruments used for the tests shall be traceable to national or international standards.

2.7.3.6 Stabilisation period

A stabilisation period for the load cell under test and the indicating instrument shall be provided, as recommended by the manufacturers of the equipment used.

2.7.3.7 Temperature conditions

It is important to allow sufficient time for temperature stabilisation of the load cell to be achieved. Particular attention shall be paid to this requirement for large load cells. The loading system shall be of a design which will not introduce significant thermal gradients within the load cell. The load cell and its connecting means (cables, tubes, etc.) which are integral or contiguous shall be at the same test temperature. The indicating instrument shall be maintained at room temperature. The temperature effect on auxiliary connecting means shall be considered in determining the results.

2.7.3.8 Barometric pressure effects

Where changes in barometric pressure may significantly affect the load cell output, such changes shall be considered.

2.7.3.9 Humidity effects

When a load cell is marked with the symbol CH or is not marked with a humidity symbol, it shall be subjected to the humidity test, as specified in 2.10.5.

When a load cell is marked with the symbol SH, it shall be subjected to the humidity test, as specified in 2.10.6.

Load cells marked with the symbol NH shall not be subjected to the humidity tests as described in 2.10.5 and 2.10.6 .

2.7.3.10 Indicating instrument checking

Some indicating instruments are provided with a convenient means for checking the indicating instrument itself. When such features are provided, they shall be utilised frequently to ensure that the indicating instrument is within the accuracy required by the test being performed. Periodic checks on the calibration status of the indicating instrument shall be performed.

2.7.3.11 Other conditions

Other conditions specified by the manufacturer such as input/output voltage, electrical sensitivity, input impedance of the indicator, etc. shall be taken into consideration during the test(s).

2.7.3.12 Time and date format

All time and date points shall be recorded such that the data can later be presented in test reports in absolute, not relative, units of local time and date. The date shall be recorded in the ISO 8601 *Data elements and interchange formats — Information interchange — Representation of dates and times* [9] (Representation of dates and times) format of ccyy-mm-dd.

NOTE: "cc" may be omitted in cases where there is no possible confusion as to the century.

2.8 Rules concerning the determination of errors

2.8.1 Conditions

The limits of error shown in Table 4 in OIML R 60-1 shall apply to all load cell measuring ranges complying with the following conditions:

$$n \leq n_{LC}$$

$$v \Rightarrow v_{\min}$$

2.8.2 Limits of error

The limits of error shown in Table 4 in OIML R 60-1 shall refer to the error envelope defined in R 60-1, 2.2 and R 60-1, 5.3.2 which is referenced to the straight line that passes through the minimum load output and the load cell output for a load of 75 % of the measuring range taken on ascending load at 20 °C. This is based upon the initial 20 °C load test. See OIML R 60-3 *Test report format for type evaluation*.

2.8.3 Initial readings

During the conduct of the tests, the initial reading shall be taken at a time interval after the initiation of loading or unloading, whichever is applicable, as specified in Table 1.

Table 1 — Combined loading and stabilisation times to be achieved prior to reading

Change in load		Time allowed for loading and stabilisation		
Greater than	Up to and including	Classes C and D	Class B	Class A
0 kg	10 kg	10 seconds	15 seconds	20 seconds
10 kg	100 kg	20 seconds	30 seconds	40 seconds
100 kg	1 000 kg	30 seconds	45 seconds	60 seconds

Table 1 (continued)

Change in load		Time allowed for loading and stabilisation		
Greater than	Up to and including	Classes C and D	Class B	Class A
1 000 kg	10 000 kg	40 seconds	60 seconds	80 seconds
10 000 kg	100 000 kg	50 seconds	75 seconds	100 seconds
100 000 kg		60 seconds	90 seconds	120 seconds

2.8.3.1 Loading/unloading times

The loading or unloading times shall be approximately half the time specified in Table 1. The remaining time shall be utilised for stabilisation. The tests shall be conducted under constant conditions. The loading or unloading time and the stabilising time shall be recorded in the test report in absolute, not relative values.

2.8.3.2 Adherence to loading/unloading times

When the specified loading or unloading times cannot be achieved, the applicant for evaluation should be consulted and the following shall apply:

- a) In the case of the minimum dead load output return test, the time may be increased from 100 % to a limit of 150 % of the specified time provided that the permissible variation of the result is proportionally reduced from 100 % to 50 % of the allowable difference between the initial reading of the minimum load output upon unloading and the reading before loading.

For example:

- 1) A change in load of 10 kg for class C and D load cells, loading (or unloading) time (approximately 5 s) is increased to 7.5 s (150 % of 5 s), MPE is reduced to 50 %; or
- 2) A change in load of 1500 kg for class C and D load cells, loading (or unloading) time (approximately 20 s) is increased to 25 s (125 % of 20 s), MPE is reduced to 75 %.

- b) In all cases, the actual times shall be recorded in the Test report.

2.9 Variation of results under reference conditions**2.9.1 Creep**

A load of D_{\max} shall be applied as specified in 2.10.2.1 to 2.10.2.7, at which time an initial reading shall be taken. The variation between the initial reading and subsequent readings of the load D_{\max} , taken as specified in 2.10.2.8, shall comply with the limits specified in R 60-1, 5.5.1.

2.9.2 Minimum dead load output return

The difference between an initial reading at a load of D_{\min} (as specified in 2.10.3.1 to 2.10.3.6) and a subsequent reading also of D_{\min} (taken after the application of a load of D_{\max} as specified in 2.10.3.7 to 2.10.3.8) shall not exceed the value in specified in R 60-1, 5.5.2.

2.10 Test procedures

Each of the tests below is presented as a “stand alone” individual test. However, for the efficient conduct of the load cell tests, it is acceptable that the increasing and decreasing load, creep, repeatability, and minimum dead load output return tests can be conducted concurrently at the given test temperature before changing to the next test temperature (see 2.11, Figures 2 and 3). The barometric pressure and the humidity tests are conducted individually following completion of the above tests.

2.10.1 Determination of measurement error, repeatability error and temperature effect on minimum dead load output

This test is applied to verify compliance with the provisions in R 60-1, 5.3, 5.4, and R 60-1, 5.6.1.3.

2.10.1.1 Check test conditions

Refer to the test conditions in 2.7.3 to ensure that proper consideration has been given to those conditions, prior to performing the following tests.

2.10.1.2 Insert load cell

Insert the load cell into the force-generating system, load to the minimum test load, D_{\min} , and stabilise at 20 °C (± 2 °C).

2.10.1.3 Preload load cell

Preload the load cell by applying the maximum test load, D_{\max} , three times, returning to the minimum test load, D_{\min} , after each load application. Wait 5 minutes before commencing with further tests.

2.10.1.4 Check indicating instrument

Check the indicating instrument according to 2.7.3.10.

2.10.1.5 Monitor load cell

Monitor the minimum test load output until stable.

2.10.1.6 Record indication

Record the indicating instrument indication at the minimum test load, D_{\min} .

2.10.1.7 Test load points

All test load points in a loading and unloading sequence shall be spaced at approximately equal time intervals. The readings shall be taken at time intervals as near as possible to those specified in Table 1 in 2.8.3. These two time intervals shall be recorded.

2.10.1.8 Apply loads

Apply increasing loads up to the maximum test load, D_{\max} . There shall be at least five increasing load points, which shall include values at or near those at which the maximum permissible error changes, as listed in Table 4 in R 60-1, 5.3.2.

2.10.1.9 Record indications

Record the indicating instrument indications at time intervals as near as possible to those specified in Table 1 in 2.8.3. These two time intervals shall be recorded.

2.10.1.10 Decrease test loads

Decrease the test loads to the minimum test load, D_{\min} , using the same load points as described in 2.10.1.8.

2.10.1.11 Record indications

Record the indicating instrument indications at time intervals as near as possible to those specified in Table 1 in 2.8.3. These two time intervals shall be recorded.

2.10.1.12 Repeat procedures for different accuracy classes

Repeat the operations described in 2.10.1.7 to 2.10.1.11 four more times for accuracy classes A and B or two more times for accuracy classes C and D.

2.10.1.13 Repeat procedures for different temperatures

Repeat the operations described in 2.10.1.3 to 2.10.1.12, first at the higher temperature, then at the lower temperature, in accordance with R 60-1, 5.6.1; then perform the operations in 2.10.1.3 to 2.10.1.12 at 20 °C (± 2 °C).

2.10.1.14 Determine magnitude of measurement error

The magnitude of the measurement error shall be determined based on the average of the results of the tests conducted at each temperature level and compared with the maximum permissible measurement errors in R 60-1, 5.3.2 (see Table 4 in OIML R 60-1).

2.10.1.15 Determine repeatability error

From the resulting data, the repeatability error may be determined and compared with the limits specified in R 60-1, 5.4.

2.10.1.16 Determine temperature effect on minimum dead load output

From the resulting data, the temperature effect on minimum dead load output may be determined and compared with the limits specified in R 60-1, 5.6.1.3.

2.10.2 Determination of creep error.

This test is applied to verify compliance with the provisions in R 60-1, 5.5.1.

2.10.2.1 Check test conditions

Refer to the test conditions in 2.7.3 to ensure that proper consideration has been given to those conditions prior to performing the following tests.

2.10.2.2 Insert load cell

Insert the load cell into the force-generating system, load to the minimum test load, D_{\min} , and stabilise at 20 °C (± 2 °C).

2.10.2.3 Preload load cell

Preload the load cell by applying the maximum test load, D_{\max} , three times, returning to the minimum test load, D_{\min} , after each load application. Wait one hour.

2.10.2.4 Check indicating instrument

Check the indicating instrument according to 2.7.3.10.

2.10.2.5 Monitor load cell

Monitor the minimum test load output until stable.

2.10.2.6 Record indication

Record the indicating instrument indication at the minimum test load, D_{\min} .

2.10.2.7 Apply load

Apply a constant maximum test load, D_{\max} (between 90 % and 100 % of E_{\max}).

2.10.2.8 Record indications

Record the initial indicating instrument indication at the time intervals specified in Table 1 in 2.8.3. Continue to record periodically thereafter, at recorded time intervals over a 30-minute period, ensuring that a reading is taken at 20 minutes.

2.10.2.9 Repeat procedures for different temperatures

Repeat the operations described in 2.10.2.2 to 2.10.2.8, first at the higher temperature, then at the lower temperature, in accordance with R 60-1, 5.6.1.

2.10.2.10 Determine creep error

With the resulting data, and taking into account the effect of barometric pressure changes according to 2.7.3.8, the magnitude of the creep error can be determined and compared with the permissible variation specified in R 60-1, 5.5.1.

2.10.3 Determination of minimum dead load output return (DR)

This test is applied to verify compliance with the provisions in R 60-1, 5.5.2.

2.10.3.1 Check test conditions

Refer to the test conditions in 2.7.3 to ensure that proper consideration has been given to those conditions prior to performing the following test.

2.10.3.2 Insert load cell

Insert the load cell into the force-generating system, load to the minimum test load, D_{\min} , and stabilise at 20 °C (± 2 °C).

2.10.3.3 Preload load cell

Preload the load cell by applying the maximum test load, D_{\max} , three times, returning to the minimum test load, D_{\min} , after each load application. Wait one hour before commencing any further tests.

2.10.3.4 Check indicating instrument

Check the indicating instrument according to 2.7.3.10.

2.10.3.5 Monitor load cell

Monitor the minimum test load output until stable.

2.10.3.6 Record indication

Record the indicating instrument indication at the minimum test load, D_{\min} .

2.10.3.7 Apply load

Apply a constant maximum test load, D_{\max} (between 90 % and 100 % of E_{\max}).

2.10.3.8 Record indications

Record the initial indicating instrument indication at time intervals as near as possible to those specified in Table 1 in 2.8.3. These two time intervals shall be recorded. Record the time at which the load is fully applied and maintain the load for a 30-minute period.

2.10.3.9 Record data

Record the time of initiation of unloading and return to the minimum test load, D_{\min} .

2.10.3.10 Record indication

Record the indicating instrument indication at time intervals as near as possible to those specified in Table 1 in 2.8.3. These two time intervals shall be recorded.

2.10.3.11 Repeat procedures for different temperatures

Repeat the operations described in 2.10.3.3 to 2.10.3.8 , first at the higher temperature, then at the lower temperature in accordance with R 60-1, 5.6.1.

2.10.3.12 Determine minimum dead load output return (DR)

With the resulting data, the magnitude of the minimum dead load output return (DR) can be determined and compared with the permissible variation specified in 2.9.2.

2.10.4 Determination of barometric pressure effects (atmospheric pressure)

This test is applied to verify compliance with the provisions in R 60-1, 5.6.2.

2.10.4.1 Check test conditions

Refer to the test conditions in 2.7.3 to ensure that proper consideration has been given to those conditions prior to performing the following test.

2.10.4.2 Insert load cell

At room temperature, insert the unloaded load cell into the pressure chamber at atmospheric pressure.

2.10.4.3 Check indicating instrument

Check the indicating instrument according to 2.7.3.10.

2.10.4.4 Monitor load cell

Monitor the output until stable.

2.10.4.5 Record indication

Record the indicating instrument indication.

2.10.4.6 Change barometric pressure

Change the barometric pressure by a minimum of 1 kPa greater than atmospheric pressure and record the indicating instrument indication.

2.10.4.7 Determine barometric pressure error

With the resulting data, the magnitude of the barometric pressure influence can be determined and compared with the limits specified in R 60-1, 5.6.2.

2.10.5 Determination of humidity effects for load cells marked CH or not marked

This test is applied to verify compliance with the provisions in R 60-1, 5.6.3.1.

2.10.5.1 Check test conditions

Refer to the test conditions in 2.7.3 to ensure that proper consideration has been given to those conditions prior to performing the following test.

2.10.5.2 Insert load cell

Insert the load cell into the force-generating system, load to the minimum test load, D_{\min} , and stabilise at 20 °C (± 2 °C).

2.10.5.3 Preload load cell

Preload the load cell by applying the maximum test load, D_{\max} , three times, returning to the minimum test load, D_{\min} , after each application. Wait 5 minutes before commencing any further tests.

2.10.5.4 Check indicating instrument

Check the indicating instrument according to 2.7.3.10.

2.10.5.5 Monitor load cell

Monitor the minimum test load output until stable.

2.10.5.6 Record indication

Record the indicating instrument indication at the minimum test load, D_{\min} .

2.10.5.7 Apply load

Apply a maximum test load, D_{\max} .

2.10.5.8 Record indications

Record the initial indicating instrument indication at time intervals as near as possible to those specified in Table 1 in 2.8.3. These two time intervals shall be recorded.

2.10.5.9 Remove load

Remove the test load to the minimum test load, D_{\min} .

2.10.5.10 Record indication

Record the indicating instrument indication at time intervals as near as possible to those specified in Table 1 in 2.8.3. These two time intervals shall be recorded.

2.10.5.11 Repeat procedures for different accuracy classes

Repeat the operations described in 2.10.5.7 to 2.10.5.10 four more times for accuracy classes A and B or two more times for accuracy classes C and D.

2.10.5.12 Conduct damp heat, cyclic test (CH)

This test is conducted to verify compliance with the provisions in R 60-1, 5.6.3.1 under conditions of high humidity combined with cyclic temperature changes

Applicable standards:

IEC 60068-2-30 [10]: *Environmental testing – Part 2: Tests*

Test Db and guidance: Damp heat cyclic (12 + 12-hour) cycle

IEC 60068-3-4 [11]: *Environmental testing—Part 2: Tests. Guidance for damp heat tests*

Test method	Exposure to damp heat with cyclic temperature variation
Test conditions	The relative humidity is between 80 % and 96 % and the temperature is varied from 25 °C to 40 °C, in accordance with the specified cycle.
Preconditioning of load cell	Load cell placed in the chamber with the output connection external to the chamber, and switched off. Use variant 2 of IEC 60068-2-30 Ed. 3.0 (2005-08) when lowering the temperature.
Initial measurements	Made according to 2.10.5.1 to 2.10.5.11
Test procedure in brief	This test consists of exposure to 12 temperature cycles of 24-hour duration each. Condensation is expected to occur on the load cell during the temperature rise. The 24 h cycle comprises: <ul style="list-style-type: none"> ▪ temperature rise during 3 hours, ▪ temperature maintained at upper value until 12 hours from the start of the cycle, ▪ temperature lowered to lower temperature level within a period of 3 to 6 hours, the declination (rate of fall) during the first hour and a half being such that the lower temperature level would be reached in a 3 hour period, ▪ temperature maintained at the lower level until the 24 h period is completed. The stabilising period before and recovery period after the cyclic exposure shall be such that the temperature of all parts of the load cell is within 3 °C of its final value. Recovery conditions and final measurements: According to 2.10.5.13 to 2.10.5.15 .

2.10.5.13 Remove load cell from chamber

Remove the load cell from the humidity chamber, carefully remove surface moisture, and maintain the load cell at standard atmospheric conditions for a period sufficient to attain temperature stability (normally 1 to 2 hours).

2.10.5.14 Repeat test procedures

Repeat 2.10.5.1 to 2.10.5.11 ensuring that the minimum test load, D_{\min} , and the maximum test load, D_{\max} , applied are the same as previously used.

2.10.5.15 Determine the magnitude of humidity-induced variations

The difference between the average of the reading of the minimum load output and of the maximum output attributed to cyclic changes in humidity as determined using test procedures in 2.10.5 shall not exceed the limits specified in R 60-1, 5.6.3.1.

The difference between the average of the reading of the maximum load, D_{\max} , attributed to cyclic changes in humidity as determined using test procedures in 2.10.5 shall not exceed the limits specified in R 60-1, 5.6.3.1.

2.10.6 Determination of humidity effects for load cells marked SH

This test is applied to verify compliance with the provisions in R 60-1, 5.6.3.2.

2.10.6.1 Check test conditions

Refer to the test conditions in 2.7.3 to ensure that proper consideration has been given to those conditions prior to performing the following tests.

2.10.6.2 Insert load cell

Insert the load cell into the force-generating system, load to the minimum test load, D_{\min} , and stabilise at 20 °C (± 2 °C).

2.10.6.3 Preload load cell

Preload the load cell by applying the maximum test load, D_{\max} , three times, returning to the minimum test load, D_{\min} , after each load application. Wait 5 minutes before commencing any further tests.

2.10.6.4 Check indicating instrument

Check the indicating instrument according to 2.7.3.10.

2.10.6.5 Monitor load cell

Monitor the minimum test load output until stable.

2.10.6.6 Record indication

Record the indicating instrument indication at the minimum test load, D_{\min} .

2.10.6.7 Test load points

All test load points in a loading and unloading sequence shall be spaced at approximately equal time intervals. The readings shall be taken at time intervals as near as possible to those specified in Table 1 in 2.8.3. These two time intervals shall be recorded.

2.10.6.8 Apply loads

Apply increasing loads up to the maximum test load, D_{\max} . There shall be at least five increasing load points which shall include loads approximating to the highest values in the applicable steps of maximum permissible measurement errors, as listed in Table 4 in R 60-1, 5.3.2.

2.10.6.9 Record indications

Record the indicating instrument indications at time intervals as near as possible to those specified in Table 1 in 2.8.3. These two time intervals shall be recorded.

2.10.6.10 Decrease load

Decrease the test load to the minimum test load, D_{\min} , using the same load points as described in 2.10.6.8.

2.10.6.11 Conduct damp heat, steady state test

This test is conducted to verify compliance with the provisions in R 60-1, 5.6.1 or R 60-1, 5.6.3 under conditions of high humidity and constant temperature.

Applicable standards:

IEC 60068-2-78: *Environmental testing—Part 2: Tests. Test Ca: Damp heat, steady state,*

Environmental testing—Part 2: Tests. Test Cb: Damp heat, steady state, primarily for equipment [12].

IEC 60068-3-4: *Environmental testing—Part 2: Tests. Guidance for damp heat tests* [11].

Test method	Exposure to damp heat in steady state
Test conditions	Relative humidity of 85 %
Preconditioning of load cell	Place the load cell in the chamber with the output connection external to the chamber, and switched on.
Test procedure in brief	<p>This test involves exposure of the load cell to a constant temperature and a constant relative humidity. The load cell shall be tested as specified in 2.10.6.1 to 2.10.6.10:</p> <ul style="list-style-type: none"> a) at a reference temperature (20 °C or the mean value of the temperature range whenever 20 °C is outside this range) and a relative humidity of 50 % following conditioning; b) at the high temperature of the range specified in R 60-1, 5.6.1 for the load cell and a relative humidity of 85 %, 48 hours following temperature and humidity stabilisation; and c) at the reference temperature and relative humidity of 50 %. The load cell shall be handled such that no condensation of water occurs on it.

2.10.6.12 Recording indications

Record the indicating instrument indications at time intervals as near as possible to those specified in Table 1 in 2.8.3. These two time intervals shall be recorded.

2.10.6.13 Determine the magnitude of humidity-induced variations

With the resulting data, the magnitude of humidity-induced variations can be determined and compared with the limits specified in R 60-1, 5.6.3.2.

2.10.7 Additional test for analogue-active load cells (disturbances)

These tests are applied to verify compliance with the provisions in R 60-1, 5.7.2.5, and R 60-1, 5.7.2.6.

2.10.7.1 Performance and stability tests

An analogue-active load cell shall pass the performance and stability tests according to 2.10.7.2 to 2.10.7.11 for the tests given in R 60-1, Table 5.

2.10.7.2 Evaluation of error for digital load cells

For load cells possessing a digital output interval greater than $0,20v$, the changeover points are to be used in the evaluation of errors, prior to rounding as follows. At a certain load, L , the digital output value, I , is noted. Additional loads, for example $0,1v$, are successively added until the output of the load cell is increased unambiguously by one digital output increment ($I + v$). The additional amount of load, ΔL , added to the load cell gives the digital output value prior to rounding, P , by using the following formula:

$$P = I + 1/2v - \Delta L$$

where:

I = the indication or digital output value;

v = the load cell verification interval; and

ΔL = additional load added to the load cell.

The error, E , prior to rounding is:

$$E = P - L = I + \frac{1}{2}v - \Delta L - L$$

and the corrected error, E_c , prior to rounding is:

$$E_c = E - E_0 \leq MPE$$

where E_0 is the error calculated at the minimum test load, D_{\min} .

2.10.7.3 Warm-up time

Test procedure in brief:

Stabilise the load cell at 20 °C ($\pm 2\text{ °C}$) and disconnect from any electrical supply for a period of at least 8 hours prior to the test.

Insert the load cell into the force-generating system.

Preload the load cell by applying a maximum test load, D_{\max} , then, returning to the minimum test load, D_{\min} , three times.

Allow the load cell to rest for 5 minutes. Connect the load cell to the power supply and switch on.

Record data:

As soon as a measurement result can be obtained, record the minimum test load output and the maximum test load, D_{\max} , applied.

Loading and unloading:

The maximum test load output shall be determined at time intervals as close as possible to those specified in Table 1 in 2.8.3 and recorded and the load should be returned to the minimum test load, D_{\min} . These measurements shall be repeated after 5, 15 and 30 minutes.

For load cells of class A, the provisions of the operating manual for the time following connection to electrical supply shall be observed.

2.10.7.4 Power voltage variations

This test is applied to verify compliance with R 60-1, 5.7.2.2, R 60-1, 5.7.2.3, and R 60-1, 5.7.2.4 under conditions of variations in voltage to the load cell's power supply.

Applicable standards:

For load cells powered by AC mains: IEC/TR3 61000-2-1 [13], IEC 61000-4-1 (set-up) [14]

For load cells powered by DC mains: IEC 61000-4-29 [15], IEC 61000-4-1 (set-up) [14]

Test method	Subject load cell to variations of power supply voltage
Test conditions	In accordance with 2.7.3.1 Environmental conditions
Preconditioning of load cell	Stabilise load cell under constant environmental conditions
Test level	<p>Mains power voltage variations:</p> <ul style="list-style-type: none"> ▪ upper voltage limit ($V + 10\%$); ▪ lower voltage limit ($V - 15\%$) <p>Battery power voltage variations:</p> <ul style="list-style-type: none"> ▪ upper voltage limit (not applicable); ▪ lower power voltage: (specified by the manufacturer, below V) <p>The voltage, (V) is the value specified by the manufacturer. If a range of reference mains power voltage (V_{\min}, V_{\max}) is specified, then the test shall be performed at an upper voltage limit of V_{\max} and a lower voltage limit of V_{\min}.</p>
Test procedure in brief	<p>This test consists of subjecting the load cell to variations of power voltage.</p> <p>A load test is performed in accordance with 2.10.1.1 to 2.10.1.12 at $20\text{ °C} (\pm 2\text{ °C})$, with the load cell powered at reference voltage. The test is repeated with the load cell powered at the upper limit and at the lower limit of power voltage.</p>

2.10.7.5 Short-time power reductions (see R 60-1, 5.7.2.5 Disturbances)

This test is conducted to verify compliance with R 60-1, 5.7.2.2, R 60-1, 5.7.2.3, and R 60-1, 5.7.2.4 under conditions of short-time power reductions

Applicable standards:

For load cells powered by DC mains: IEC 61000-4-29 [15]; IEC 61000-4-1 [14]

For load cells powered by AC mains; IEC 61000-4-11 [16]; IEC 61000-6-1 [17]; IEC 61000-6-2 [18]

Test method	Expose load cell to specified short-timer power reductions
Test conditions	In accordance with 2.7.3.1 Environmental conditions
Preconditioning of load cell	Stabilise load cell under constant environmental conditions

Test load	The test shall be performed with no load or with one small test load (10 v).																							
Test level	<table border="1"> <thead> <tr> <th>Test</th> <th>Reduction to:</th> <th>Duration/number of cycles</th> </tr> </thead> <tbody> <tr> <td>Test a</td> <td>0 %</td> <td>0.5</td> </tr> <tr> <td>Test b</td> <td>0 %</td> <td>1</td> </tr> <tr> <td>Test c</td> <td>40 %</td> <td>10</td> </tr> <tr> <td>Test d</td> <td>70 %</td> <td>25</td> </tr> <tr> <td>Test e</td> <td>80 %</td> <td>250</td> </tr> <tr> <td>Short interruption</td> <td>0 %</td> <td>250</td> </tr> </tbody> </table>			Test	Reduction to:	Duration/number of cycles	Test a	0 %	0.5	Test b	0 %	1	Test c	40 %	10	Test d	70 %	25	Test e	80 %	250	Short interruption	0 %	250
	Test	Reduction to:	Duration/number of cycles																					
	Test a	0 %	0.5																					
	Test b	0 %	1																					
	Test c	40 %	10																					
	Test d	70 %	25																					
	Test e	80 %	250																					
	Short interruption	0 %	250																					
Test procedure in brief	A test generator capable of reducing the amplitude of one or more half cycles (at zero crossings) of the AC mains voltage shall be used. The test generator shall be adjusted before connecting to the load cell. The load cell shall be exposed to short interruptions of power. The mains voltage reductions shall be repeated ten times at intervals of at least 10 seconds.																							

2.10.7.6 Bursts (electrical fast transients) (see R 60-1, 5.7.2.5 Disturbances)

This test is conducted to verify compliance with the provisions in R 60-1, 5.7.2.5 during conditions where electrical bursts are superimposed on the mains voltage.

Applicable standards:

IEC 61000-4-4 [19]: No. 5 (Test 2+| severity), No. 6 (Test instrumentation), No. 7 (Test set-up), No. 8 (Test procedure).

Test method	Introducing transients on the mains power lines
Test conditions	In accordance with 2.7.3.1 Environmental conditions
Preconditioning of load cell	Stabilise load cell under constant environmental conditions
Test level	Level 3 in accordance with referenced standard: IEC 61000-4-4 No.5 Open circuit output test voltage for: <ul style="list-style-type: none"> ▪ power supply lines: 2 kV; ▪ I/O signal, data, and control lines: 1 kV.
Test load	The test shall be performed with no load or with one small test load
(10 v).	Test procedure in brief This test consists of exposing the load cell to specified bursts of voltage spikes. A burst generator as defined in the referred standard [IEC 61000-4-4 Ed 3.0 (2012-04)] shall be used. The characteristics of the generator shall be verified before connecting the EUT.

	<p>The test shall be applied separately to:</p> <p>a) power supply lines;</p> <p>b) I/O circuits and communication lines, if any.</p>
--	---

2.10.7.7 Surge (see R 60-1, 5.7.2.5 Disturbances)

This test is conducted to verify compliance with the provisions in R 60-1, 5.7.2.5 during conditions where electrical surges are superimposed on the mains voltage and I/O and communication ports.

Applicable standards:

IEC 61000-4-5 [20]

Test method	Exposing the load cell(s) to electrical surges on the mains power lines or on signal, data and control lines
Test conditions	In accordance with 2.7.3.1 Environmental conditions
Preconditioning of load cell	Stabilise load cell under constant environmental conditions
Test level	Level 3 Amplitude (peak value) Power supply lines: 1 kV (line to line) and 2 kV (line to earth)
Test load	The test shall be performed with no load or with one small test load (10v).
Test procedure in brief	<p>This test is only applicable in those cases where, based on typical situations of installation, the risk of a significant influence of surges can be expected. This is especially relevant in cases of outdoor installations and/or indoor installations connected to long signal lines (lines longer than 10 m or those lines partially or fully installed outside the buildings regardless of their length).</p> <p>This test shall be conducted unless there is justification provided regarding the specific details of the intended use and installation which would render this test unnecessary. The justification for not conducting this test shall be noted in the test report.</p> <p>The test is applicable to power lines, communication lines (internet, dial up modem, etc.), and other lines for control, data or signal mentioned above (lines to temperature sensors, gas or liquid flow sensors, etc.).</p> <p>The test consists of exposing the load cell to surges for which the rise time, pulse width, peak values of the output voltage/current on high/low impedance load and minimum time interval between two successive pulses are defined in the referenced standard. The characteristics of the generator shall be adjusted before connecting the load cell.</p> <p>The test shall be applied to power supply lines, communication lines (internet, dial-up modem, etc.), and other lines for control, data or signal mentioned above (lines to temperature sensors, gas or liquid flow sensors, etc.).</p> <p>On AC mains supply lines at least 3 positive and 3 negative surges shall be applied synchronously with AC supply voltage in angles 0°, 90°, 180° and 270°. On any other kind of power supply, at least three positive and three negative surges shall be applied.</p>
Notes	Both positive and negative polarity of the surges shall be applied. The duration of the test shall not be less than one minute for each amplitude and polarity.

	The injection network on the mains shall contain blocking filters to prevent the surge energy being dissipated in the mains.
--	--

2.10.7.8 Electrostatic discharge (see R 60-1, 5.7.2.5 Disturbances)

This test is conducted to verify compliance with the provisions in R 60-1, 5.7.2.5 in case of direct exposure to electrostatic discharges or such discharges in the neighbourhood of the load cell.

Applicable standard:

IEC 61000-4-2 [21]: No. 6 (test generator), No. 7 (set-up), No. 8 (test procedure).

Test method	Exposure to electrostatic discharge (ESD)
Test conditions	In accordance with 2.7.3.1 Environmental conditions
Preconditioning of the load cell	Stabilise the load cell under constant environmental conditions
Test procedure in brief	<p>The test comprises exposure of the load cell to electrical discharges.</p> <p>An ESD generator as defined in the referred standard shall be used and the test set-up shall comply with the dimensions, materials used and conditions as specified in the referred standard. Before starting the tests, the performance of the generator shall be verified.</p> <p>At least 10 discharges per preselected discharge location shall be applied. The time interval between successive discharges shall be at least 10 seconds.</p> <p>This test includes the paint penetration method, if appropriate;</p> <p>For direct discharges, the air discharge shall be used where the contact discharge method cannot be applied.</p> <p>Contact discharge is the preferred test method. Air discharge is far less defined and reproducible and therefore shall be used only where contact discharge cannot be applied.</p> <p>Direct application:</p> <p>In the contact discharge mode to be carried out on conductive surfaces, the electrode shall be in contact with the EUT before activation of the discharge. In such case the discharge spark occurs in the vacuum relays of the contact discharge tip.</p> <p>On insulated surfaces only the air discharge mode can be applied. The load cell is approached by the charged electrode until a spark discharge occurs</p> <p>Indirect application:</p> <p>The discharges are applied in the contact mode only on coupling planes mounted in the vicinity of the load cell.</p> <p>For load cells not equipped with a ground terminal, the load cell shall be fully discharged between discharges.</p>
Test severity	Level 3 (in accordance with IEC 61000-4 -2 (2008-12) Ed 2.0 Consolidated edition, No. 5). DC voltage up to and including 6 kV for contact discharges and 8 kV for air discharges.
Test load	The test shall be performed with no load or with one small test load (10v)

2.10.7.9 Exposure to radiated RF electromagnetic fields (see R 60-1, 5.7.2.5 Disturbances)

This test is conducted to verify compliance with the provisions in R 60-1, 5.7.2.5 under conditions of exposure to electromagnetic fields.

Applicable standard:

IEC 61000-4-3 [22]: No. 6 (test generator), No. 7 (test set-up), No. 8 (test procedure)

Test method	Exposure to specified electromagnetic fields
Test conditions	In accordance with 2.7.3.1 Environmental conditions
Preconditioning of the load cell	Stabilise the load cell under constant environmental conditions.
Test procedure in brief	<p>The load cell is exposed to electromagnetic fields with the required field strength and the field uniformity as defined in the referred standard.</p> <p>The level of field strength specified refers to the field generated by the unmodulated carrier wave.</p> <p>The load cell shall be exposed to the modulated wave field. The frequency sweep shall be made only pausing to adjust the RF signal level or to switch RF-generators, amplifiers and antennas if necessary. Where the frequency range is swept incrementally, the step size shall not exceed 1 % of the preceding frequency value.</p> <p>The dwell time of the amplitude modulated carrier at each frequency shall not be less than the time necessary for the load cell to be exercised and to respond, but shall in no case be less than 0.5 s.</p> <p>Adequate EM fields can be generated in facilities of different type and set-up the use of which is limited by the dimensions of the load cell and the frequency range of the facility.</p>
Test load	The test shall be performed with no load or with one small test load (10 v).
Test levels	<p>Level 3:</p> <p>Frequency range: 80 MHz^a to 3 000 MHz;</p> <p>Field strength: 10 Vm⁻¹;</p> <p>Modulation: 80 % AM, 1 kHz sine wave.</p>
<p>^a Frequency range used in conventional testing shall be 80 MHz to 3 000 MHz, for load cells with power lines or I/O ports. The lower limit of frequency of electromagnetic field is 26 MHz for load cells without power lines or I/O ports, and for which the test for conducted electromagnetic field (2.10.7.10) is inapplicable.</p>	

2.10.7.10 Exposure to conducted (common mode) currents generated by RF EM fields (see R 60-1, 5.7.2.5 Disturbances)

This test is conducted to verify compliance with the provisions in R 60-1, 5.7.2.5 while exposed to electromagnetic fields

Applicable standard: IEC 61000-4-6 [23]

Test method	Exposure of the load cell to disturbances induced by radiated radio-frequency fields.
-------------	---

Test conditions	In accordance with 2.7.3.1 Environmental conditions
Preconditioning of the load cell	Stabilise the load cell under constant environmental conditions.
Test procedure in brief	A RF EM current, simulating the influence of EM fields shall be coupled or injected into the power ports and I/O ports of the load cell using coupling/decoupling devices as defined in the referred standard. The characteristics of the test equipment consisting of an RF generator, (de-)coupling devices, attenuators, etc. shall be verified before connecting the load cell.
Test load	The test shall be performed with no load or with one small test load (10v).
Test level index	Level 3 (in accordance with the referred standard) Frequency range: 0,15 MHz—80 MHz RF amplitude (50 Ω): 10 V(emf) Modulation: 80 % AM, 1 kHz, sine wave
Notes	This test is not applicable for load cells without mains power supply or other input port.

2.10.7.11 Span stability (see R 60-1, 5.7.2.6) (not applicable to class A load cells)

Test procedure in brief:

The test consists in observing the variations of the output of the load cell under reasonably constant (± 2 °C) conditions (e.g. in a normal laboratory environment) at various intervals before, during and after the load cell has been subjected to performance tests. The performance tests shall include (as a minimum) the temperature test. The damp heat test shall be performed when applicable but may be performed after a series of span stability tests if the conduct of that test during the span stability test imposes an increased risk that the principles expressed under 2.7.3.3. would be compromised. This may be a greater concern when conducting tests on higher capacity load cells.

The load cell shall be disconnected from the mains power supply, or battery supply where fitted, two times for at least 8 hours during the period of test. The number of disconnections may be increased if the manufacturer specifies so or at the discretion of the approval authority in the absence of any such consideration.

For the conduct of this test, the manufacturer's operating instructions shall be considered.

The load cell shall be stabilised at sufficiently constant ambient conditions after switch-on for at least 5 hours, but at least 16 hours after any temperature or humidity tests have been performed.

Test duration:

28 days or the period necessary for the performance tests to be carried out, whichever is shorter, for temperature and humidity tests.

The duration may be increased to 40 days for CH marked load cells only.

Time between measurements:

Between 1/2 day (12 hours) and 10 days (240 hours) for SH marked load cells, and 14 days for CH marked load cells, with an even distribution of the measurements over the total duration of the test.

Test loads:

A minimum test load, D_{\min} ; the same test load shall be used throughout the test.

A maximum test load, D_{\max} ; the same test load shall be used throughout the test.

Number of measurements: At least 8.

Test sequence:

Identical test equipment and test loads shall be used throughout the test.

Stabilise all factors at sufficiently constant ambient conditions.

Each set of measurements shall consist of the following:

- a) preload the load cell by applying the maximum test load, D_{\max} , three times, returning to the minimum test load, D_{\min} , after each load application;
- b) stabilise the load cell at the minimum test load, D_{\min} ;
- c) read the minimum test load output and apply the maximum test load, D_{\max} . Read the maximum test load output at time intervals as near as possible to those specified in Table 1 in 2.8.3, and return to the minimum test load, D_{\min} . Repeat this four more times for accuracy class B or two more times for accuracy classes C and D;
- d) determine the span measurement result, which is the difference in output between the mean maximum test load outputs and the mean minimum test load outputs. Compare subsequent results with the initial span measurement result and determine the error.

Record the following data:

- a) date and time (absolute, not relative);
- b) temperature;
- c) barometric pressure;
- d) relative humidity;
- e) test load values;
- f) load cell outputs;
- g) errors.

Apply all necessary corrections resulting from variations in temperature, pressure, etc. between the various measurements.

Allow for full recovery of the load cell before any other tests are performed.

Where differences of results indicate a trend of more than half the allowable variation specified above, the test shall be continued until the trend comes to rest or reverses itself, or until the error exceeds the maximum allowable variation.

2.11 Test sequence

2.11.1 Test sequence for test temperatures

The recommended test sequence for each test temperature when all tests are carried out in the same force-generating system is shown in Figure 2.

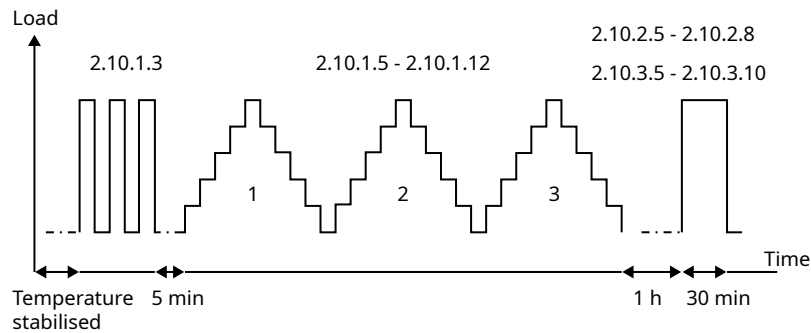

Figure 2 — Recommended test sequence for each test temperature when all tests are carried out in the same force-generating system

2.11.2 Test sequence for minimum dead load output return

The recommended test sequence for each test temperature for the minimum dead load output return (DR) and creep tests when carried out in a force-generating system different to that used for the load tests is shown in Figure 3.

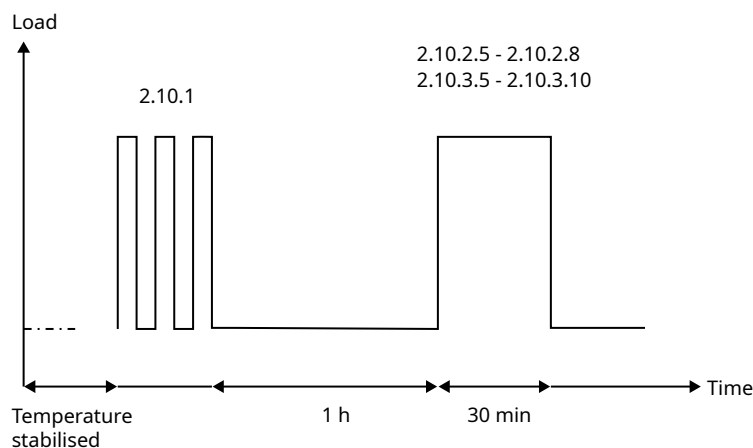

Figure 3 — Recommended test sequence for each test temperature for the minimum dead load output return (DR) and creep tests when carried out in a machine different from that used for the load tests

2.12 OIML certificate

2.12.1 Preparation of certificate

The OIML certificate shall be prepared according to the rules contained within OIML B 18 *Framework for the OIML Certification System (OIML-CS)* [6] and OIML-CS Procedural Document PD-05 [29]. The certificate template (which may be downloaded from the “Documentation” section under the OIML-CS part of the OIML website) shall be supplemented with the information as specified in Annex B. In addition, Annex C provides an example of the supplemental information that may be included in the OIML certificate and is included in this Recommendation to complement the template.

2.12.2 Reference of values on certificate

Regardless of the evaluation result of any load cell in a load cell family, the certificate to be issued should not provide for any characteristics or values which are beyond those that the manufacturer has

requested and for which the manufacturer intends to guarantee, for example, by expressing the relevant characteristics and values in its data sheet.

Metrological regulation for load cells

Part 3: Test report format

Réglementation métrologique des cellules de pesée

Format du rapport d'essais



Contents

Foreword		62
1 Introduction		63
2 Applicability of this Report Format		63
2.1 Calculation procedures.....		63
2.2 Additional tests for digital load cells.....		68
2.3 General notes.....		70
2.4 Formula signs and list of symbols.....		71
2.5 Summary of formulae contained within calculation procedures.....		72
3 Guidance for the application of this Test Report Format		72
4 The Evaluation Report		73
4.1 Authority responsible for this Report.....		74
4.2 Synopsis of the results of the examination and tests.....		74
4.3 Summary of the results of the examination and tests.....		74
4.4 General information regarding the evaluation process.....		75
4.5 General information concerning the load cell type.....		77
4.6 Accessories, supplied with the test pattern by the applicant.....		77
4.7 Selection of sample(s) tested.....		78
4.8 Adjustments and modifications made to the samples during the testing.....		79
4.9 Additional information concerning the type.....		79
4.10 Information concerning the test equipment used for the tests.....		85
5 Examination		94
5.1 Marking requirements (R 60-1, 6.2).....		94
5.2 Suitability for testing (R 60-2, 2.3, 2.4).....		96
5.3 Software (if present) (R 60-1, 6.1).....		96
5.4 Documentation for type approval (R 60-2, 2.5).....		97
6 Performance tests		98
6.1 Results of the performance tests.....		98
6.2 Initial tests and general notes concerning performance tests.....		99
6.3 Load test data (Load cell error E_L) 3 runs.....		101
6.4 Load test data (Load cell error E_L) 5 runs.....		104
6.5 Load cell errors (E_L) calculation.....		107
6.6 Repeatability errors (E_R) calculation.....		108
6.7 Temperature effects on minimum dead load output (MDLO).....		110
6.8 Creep (C_C) and DR (C_{DR}).....		111
6.9 Barometric pressure effects (C_P).....		114
6.10 Humidity effects.....		115
6.11 Warm-up time.....		130
6.12 Power voltage variation.....		131
6.13 Short time power reductions.....		133
6.14 Bursts (electrical fast transients).....		134
6.15 Surges.....		137
6.16 Electrostatic discharge.....		139
6.17 Electromagnetic susceptibility.....		142
6.18 Immunity to conducted electromagnetic fields.....		145
6.19 Span stability.....		148

Foreword

The International Organisation of Legal Metrology (OIML) is a worldwide, intergovernmental organisation whose primary aim is to harmonise the regulations and metrological controls applied by the national metrological services, or related organisations, of its Member States. The main categories of OIML publications are:

- **International Recommendations (OIML R)**, which are model regulations that establish the metrological characteristics required of certain measuring instruments and which specify methods and equipment for checking their conformity. OIML Member States shall implement these Recommendations to the greatest possible extent;
- **International Documents (OIML D)**, which are informative in nature and which are intended to harmonise and improve work in the field of legal metrology;
- **International Guides (OIML G)**, which are also informative in nature and which are intended to give guidelines for the application of certain requirements to legal metrology;
- **International Basic Publications (OIML B)**, which define the operating rules of the various OIML structures and systems; and

OIML Draft Recommendations, Documents and Guides are developed by Project Groups linked to Technical Committees or Subcommittees which comprise representatives from OIML Member States. Certain international and regional institutions also participate on a consultation basis. Cooperative agreements have been established between the OIML and certain institutions, such as ISO and the IEC, with the objective of avoiding contradictory requirements. Consequently, manufacturers and users of measuring instruments, test laboratories, etc. may simultaneously apply OIML publications and those of other institutions.

International Recommendations, Documents, Guides and Basic Publications are published in English (E) and translated into French (F) and are subject to periodic revision.

Additionally, the OIML publishes or participates in the publication of **Vocabularies (OIML V)** and periodically commissions legal metrology experts to write **Expert Reports (OIML E)**. Expert Reports are intended to provide information and advice, and are written solely from the viewpoint of their author, without the involvement of a Technical Committee or Subcommittee, nor that of the CIML. Thus, they do not necessarily represent the views of the OIML.

This publication—reference OIML R 60-3:2021—is an updated edition (developed by the OIML Certification System Management Committee) of R 60-3:2017 (developed by Project Group 1 of OIML Technical Committee TC 9 *Instruments for measuring mass and density*). This updated edition consolidates the Amendment (2019-12-23) to R 60:2017, and includes other editorial and minor technical changes. It was approved for final publication by the International Committee of Legal Metrology at its 56th meeting in October 2021 and was sanctioned by the 16th International Conference on Legal Metrology in 2021. It supersedes the previous edition of R 60 dated 2017.

OIML Publications may be downloaded from the OIML web site in the form of PDF files. Additional information on OIML Publications may be obtained from the Organisation's headquarters:

Bureau International de Métrologie Légale
11, rue Turgot — 75009 Paris — France
Telephone: 33 (0)1 48 78 12 82
Fax: 33 (0)1 42 82 17 27
E-mail: biml@oiml.org
Internet: www.oiml.org

Part 3 - Test report format

1 Introduction

1.1 This Report Format applies to any kind of load cell (independent of its technology). It presents a standardised format for the results of the various tests and examinations, described in OIML R 60-2, to which a type of load cell shall be submitted for the purpose of its approval based on this OIML Recommendation.

1.2 It is recommended that all metrology services or laboratories evaluating and/or testing types of load cells according to OIML R 60-1, or to national or regional regulations based on this Recommendation, use this Report Format, directly or after translation into a language other than English or French. In the case of a translation, it is highly recommended to leave the structure and the numbers of the clauses unchanged: in this case, most of the content is also understandable for those who cannot read the language of the translation.

1.3 Some of the tests may have to be repeated several times and reported using several identical sheets; therefore, report pages must be numbered in the space provided at the top of each page, completed by the indication of the total number of pages.

1.4 In the practical application of the Report Format, in addition to a cover page by the Issuing Authority, as a minimum, clauses A-F (as necessary) shall be included.

2 Applicability of this Report Format

In the framework of OIML B 18 *Framework for the OIML Certification System (OIML-CS)* [6] applicable to load cells in conformity with OIML R 60-1 and R 60-2, use of this Report Format is mandatory, in French and/or in English with translation into the national languages of the countries issuing such certificates, if appropriate.

Implementation of this Report Format is informative with regard to the implementation of OIML R 60-1 and R 60-2 in national regulations.

2.1 Calculation procedures

2.1.1 In order to facilitate a comparison of the reports established in English and in French, the same abbreviations (those of the English language) are used in both versions; the meanings of these abbreviations are given whenever appropriate.

In testing and evaluating load cells for type evaluation, it is recognised that the test apparatus and practices used by the various laboratories will be different. OIML R 60 allows for these variations and still provides a method for testing, recording and calculating results that are readily understandable by other knowledgeable parties reviewing the data.

In order to achieve this ease of comparability it is necessary that those persons conducting the tests use a common system for recording data and calculating results.

Thus, it is essential that the calculation procedures below be reviewed and followed closely in the completion of this test report.

2.1.2 Load cell errors ($E_L = \text{Error Load test}$)

2.1.2.1 Complete a Table 1 for each test temperature, calculate the averages and record in the right-hand column. When five runs are necessary, use Table 2.

2.1.2.2 Determine the conversion factor, f , which is the number of indicated units per load cell verification interval, v , and is used to convert all “indicated units” to “ v ”. It is determined from the test data averages of the increasing load tests at the initial 20 °C nominal test temperature.

2.1.2.3 If a test load corresponding to 75 % of the measuring range for the load cell under test (i.e. 2 250 divisions for a 3 000 division cell, which is D_{\min} plus 75 % of the difference between D_{\max} and D_{\min}) is not included in the test loads used in Table 1, interpolate between the adjacent upper and lower values of the averages of all three test runs and record in Table 3 (see R 60-2, 2.8.2).

2.1.2.4 Calculate the difference between the average indication on the increasing load test runs at 75 % of the difference between D_{\max} and D_{\min} and the indication at D_{\min} . Divide the result (to five significant figures) by the number of verification intervals (75 % of n) for that load to obtain the conversion factor, f , and record in the tables that follow.

$$f = \frac{\text{average indication at } 0.75 \cdot (D_{\max} - D_{\min}) - \text{indication at } D_{\min}}{0.75 \cdot n}$$

The units of conversion factor, f , are indicated units (e.g. digits or counts) per load cell verification interval, v .

2.1.2.5 Enter the average test indications of the tests at the temperatures following the initial test at a nominal 20 °C in Table 3. In recording this data, indicate a “no test load” indication (at D_{\min}) as “0”. This may require subtracting the “no load indication at D_{\min} ” from the “test load indication” so that the first entry in the column is “0”. These “0’s” have been preprinted on the form to clarify that a dead load condition is recorded as “0”.

2.1.2.6 Calculate the reference indication, R_i , by converting the net test load, in mass units, to indicated units (e.g. counts or digits), by multiplying by the conversion factor, f , for each test load and recording in the 2nd column in Table 3.

$$R_i = \frac{(\text{test load } i - D_{\min})}{(D_{\max} - D_{\min})} \cdot n \cdot f$$

2.1.2.7 In Table 3 calculate the difference between the average test indication and the reference indication for each test load at each test temperature and divide the result by the conversion factor, f , to obtain the error, E_L , for each test load in terms of v .

$$E_L = (\text{average test indication for test load } i - \text{reference indication } R_i) / f$$

2.1.2.8 Compare E_L with the corresponding MPE for each test load.

2.1.3 Repeatability error (E_R in terms of verification interval, v)

2.1.3.1 Enter data in Table 4.

2.1.3.2 Calculate the maximum difference between the test indications on Form 6.3 and divide it by f to obtain the repeatability error, E_R , in terms of the load cell verification interval, v .

$$E_R = (\text{maximum indication of the test load} - \text{minimum indication}) / f$$

2.1.3.3 Compare E_R with the absolute value of the corresponding MPE for each test load.

2.1.4 Temperature effects on minimum dead load output (MDLO) ($C_M = \text{Change MDLO}$)

2.1.4.1 Enter in Table 5 the average indication for the initial minimum test load, D_{\min} , for each test temperature from Table 1.

2.1.4.2 Calculate the difference between the average test indications for each temperature T_i in sequence and divide the result by the conversion factor, f , to obtain the change in terms of the load cell verification interval, v .

$$C_M = (\text{average test indication at } T_2 - \text{average indication at } T_1) / f$$

2.1.4.3 Divide C_M by $(T_2 - T_1)$ and multiply the result by a factor $T_f = 5$ for class B, C, and D load cells or $T_f = 2$ for class A load cells. This gives the change in v per 5 °C for class B, C, and D load cells or in v per 2 °C for class A load cells.

2.1.4.4 Multiply the result by $[(D_{\max} - D_{\min}) / n / v_{\min}]$ to give the final result $C_M(v_{\min})$ in units of v_{\min} per 5 °C for class B, C, and D load cells, or in units of v_{\min} per 2 °C for class A load cells. $C_M(v_{\min})$ must not exceed p_{LC} .

$$C_M(v_{\min}) = \left| \frac{C_M \cdot T_f}{(T_2 - T_1)} \times \frac{(D_{\max} - D_{\min})}{n \cdot v_{\min}} \right|$$

$$C_M(v_{\min}) \leq p_{LC}$$

2.1.5 Creep magnitude $C_C(t)$ and minimum dead load output return (C_{DR})

$(C_C(t) = \text{Creep, expressed in terms of the load cell verification interval, } v)$

$(C_{DR} = DR, \text{ expressed in terms of the load cell verification interval, } v)$

Remark: Contrary to the minimum dead load output return DR in terms of mass the minimum dead load output C_{DR} is expressed in terms of the verification interval, v .

From the test indications recorded in Table 6, calculate the difference between the initial indication obtained at the minimum creep test load after the stabilisation period and any indication obtained over the 30 minute test period with the maximum creep test load of 90 % to 100 % of E_{\max} and divide by the conversion factor, f .

$$C_C(t) = (\text{indication} - \text{initial indication}) / f$$

Remark: If the minimum creep test load or the maximum creep test load differ from D_{\min} or D_{\max} according to 2.1.2 “Load cell errors E_L ” the conversion factor, f , must be recalculated with the minimum and maximum creep test loads (see 2.1.2.4).

2.1.5.1 $C_C(t)$ must not exceed 0.7 times the absolute value of the MPE for the maximum creep test load at any time t over the 30 minute creep test period.

2.1.5.2 Calculate the difference between the test indications obtained at $t = 20$ minutes and $t = 30$ minutes after the initial indication at $t = t_0$ and divide by f to obtain the creep error, $C_C(30 - 20)$, in terms of the load cell verification interval, v .

$$C_C(30 - 20) = (\text{indication at time } t = 30 \text{ minutes} - \text{indication at time } t = 20 \text{ minutes}) / f$$

2.1.5.3 $C_C(30 - 20)$ shall not exceed 0.15 times the absolute value of the MPE for the applied load.

2.1.5.4 Calculate the difference between the initial indication obtained at the minimum creep test load after the stabilisation period ($t_0 = 0$ min) and the indication at the minimum creep test load after the creep test and after a time interval for stabilisation ($t > 30$ min) and divide the result by conversion factor, f , to obtain the minimum dead load output return, C_{DR} , in terms of v .

$$C_{DR} = (\text{minimum test load indication}_2 - \text{minimum test load indication}_1) / f$$

2.1.5.5 If the time intervals specified in R 60-2, Table 1 have been met, C_{DR} must not exceed $0.5 v$.

2.1.5.6 If the actual time is between 100 % and 150 % of the specified time in R 60-2, Table 1, then the following applies:

$$C_{DR} \leq 0.5 (1 - (x - 1))v$$

with

$x = \text{actual time} / \text{specified time}$

2.1.5.7 Whereas C_{DR} expresses the minimum dead load output return in terms of v , the value of DR as used in OIML R 76 [1] is expressed in units of mass (g, kg or t).

2.1.5.8 Calculate the minimum dead load output return, DR , expressed in units of mass (g, kg or t) as follows: $DR = (E_{\max} - E_{\min})C_{DR} / n_{LC}$

2.1.5.9 Regardless of the value declared by the manufacturer for the apportionment factor, p_{LC} , the MPE for creep shall be determined from R 60-1, Table 4 using the apportionment factor, $p_{LC} = 0,7$ (see R 60-1, 5.5.1).

2.1.6 Barometric pressure effects¹⁾ (C_p = Change due to barometric pressure)

2.1.6.1 From the test indications recorded in R 60-3, Table 7, calculate the difference between the indications for each pressure and divide the result by conversion factor, f , to obtain the change, C_p , in terms of v .

$$C_p = (\text{indication at } P_2 - \text{indication at } P_1) / f$$

2.1.6.2 Divide C_p by $(P_2 - P_1)$ to determine the change due to barometric pressure in terms of v per kilopascal (kPa).

2.1.6.3 Multiply the result by $[(E_{\max} - E_{\min}) / n_{LC}]$ to obtain the result in units of mass (g, kg, or t) per kPa (as stated by the manufacturer). The result must not exceed v_{\min} .

$$C_p (v) = \frac{C_p}{(P_2 - P_1)} \cdot \frac{(E_{\max} - E_{\min})}{n_{\max}} \leq v_{\min}$$

2.1.7 Humidity effects²⁾ (CH or no mark)

($C_{H\min}$ = Change in terms of v due to Humidity effect on the indication of the minimum test load D_{\min})

($C_{H\max}$ = Change due to Humidity effect on the indication of the maximum test load D_{\max})

Remark: If the minimum or maximum test load used for this test differ from the minimum test load D_{\min} or maximum test load D_{\max} according to R 60-3, 2.1.2 “Load cell errors E_L ” the conversion factor, f , must be recalculated with the minimum and maximum test loads of this test (see R 60-3, 2.1.2.4).

2.1.7.1 From the test indications recorded in R 60-3, Table 6.10.1, calculate the difference between the initial indications for the minimum test load, D_{\min} , before and after the damp heat test and divide the result by conversion factor, f , to obtain the change, $C_{H\min}$, in terms of verification interval, v (see R 60-1, 5.6.3.1).

$$C_{H\min} = [(\text{indication at } D_{\min})_{\text{after}} - (\text{indication at } D_{\min})_{\text{before}}] / f$$

$C_{H\min}$ must not exceed $0.04 \cdot n$.

2.1.7.2 Calculate the average indications $\bar{I}\{D_{\max}\}$ and $\bar{I}\{D_{\min}\}$ at D_{\min} (see R 60-2, 2.10.5) for the required number of test indications, before and after the damp heat test. Subtract $\bar{I}\{D_{\min}\}$ from $\bar{I}\{D_{\max}\}$ for the tests before and after damp heat test and then calculate the difference between the results. Divide the result by the conversion factor, f , to obtain the change, $C_{H\max}$ in terms of v .

1) This test may not be necessary depending on the design of the load cell.

2) This test is not necessary if the load cell is marked NH or SH.

$$C_{H_{\max}} = \frac{[(\bar{I}\{D_{\max}\} - \bar{I}\{D_{\min}\})_{\text{after}} - (\bar{I}\{D_{\max}\} - \bar{I}\{D_{\min}\})_{\text{before}}]}{f}$$

2.1.7.3 $C_{H_{\max}}$ must not exceed the MPE (see R 60-1, Table 4 in 5.3.2).

2.1.8 Humidity effects³⁾ (SH)

Report load test errors at different temperatures and humidity conditions using R 60-3, Forms 6.3, then indicate the results in R 60-3, Table 6.10.2 utilising the procedure contained within “load cell errors” procedure, R 60-3, 2.1.2, in a manner similar to that used for the preparation of R 60-3, Table 6.5.

2.2 Additional tests for digital load cells

2.2.1 Warm-up time

2.2.1.1 Enter data on R 60-3, Form 6.11 (Warm-up time).

2.2.1.2 Span is the result of subtraction of the indication at the minimum test load, D_{\min} , from the indication at the maximum test load, D_{\max} .

2.2.1.3 Change is the difference between the span and the initial run span.

2.2.2 Power voltage variations

2.2.2.1 Enter data on R 60-3, Form 6.12.

2.2.2.2 Perform load tests and record results utilising R 60-3, Form 6.12.

2.2.2.3 Calculate reference indications in accordance with the “load cell errors” procedure, R 60-3, 2.1.2.

2.2.2.4 Indicate results on R 60-3, Form 6.12.

2.2.3 Short-time power reductions

2.2.3.1 Enter data on R 60-3, Form 6.13.

2.2.3.2 Calculate the difference, which is:

$$\text{difference} = \frac{(\text{indication with disturbance, in units} - \text{indication without disturbance, in units})}{\text{conversion factor, } f}$$

3) This test is not necessary if the load cell is marked NH or CH or has no humidity marking.

2.2.3.3 Indicate results on R 60-3, Form 6.13.

2.2.4 Bursts (electrical fast transients)

2.2.4.1 Enter data on R 60-3, Forms 6.14.1 and 6.14.2.

2.2.4.2 Indicate results on R 60-3, Forms 6.14.1 and 6.14.2.

2.2.5 Surge

2.2.5.1 Enter data on R 60-3, Forms 6.15

$$\text{difference} = \frac{(\text{indication with disturbance, in units} - \text{indication without disturbance, in units})}{\text{conversion factor, } f}$$

2.2.5.2 Indicate results on R 60-3, Forms 6.15

2.2.6 Electrostatic discharge

2.2.6.1 Enter data on R 60-3, Forms 6.16.1, 6.16.2 and 6.16.3.

2.2.6.2 Calculate the difference, which is:

$$\text{difference} = \frac{(\text{indication with disturbance, in units} - \text{indication without disturbance, in units})}{\text{conversion factor, } f}$$

2.2.6.3 Indicate results on R 60-3, Forms 6.16.1, 6.16.2.1, and 6.16.2.2.

2.2.6.4 Provide test point information on Form 6.16.3.

2.2.7 Electromagnetic susceptibility

2.2.7.1 Enter data on R 60-3, Form 6.17.1.

2.2.7.2 Calculate the difference, which is:

$$\text{difference} = \frac{(\text{indication with disturbance, in units} - \text{indication without disturbance, in units})}{\text{conversion factor, } f}$$

2.2.7.3 Indicate results on R 60-3, Form 6.17.1.

2.2.7.4 Provide test set-up information on R 60-3, Form 6.17.2.

2.2.8 Immunity to conducted electromagnetic fields

2.2.8.1 Enter data on R 60-3, Form 6.18.

2.2.8.2 Calculate the difference, which is:

$$\text{difference} = \frac{(\text{indication with disturbance, in units} - \text{indication without disturbance, in units})}{\text{conversion factor, } f}$$

2.2.8.3 Indicate results on R 60-3, Form 6.18.

2.2.8.4 Provide test setup information on R 60-3, Form 6.18.

2.2.9 Span stability

2.2.9.1 Enter data on R 60-3, Forms 6.19.1 (3 runs) to 6.19.2 (5 runs).

2.2.9.2 Calculate averages and record on R 60-3, Forms 6.19.1 (3 runs) to 6.19.2 (5 runs).

2.2.9.3 Indicate results on R 60-3, Form 6.19.3

2.3 General notes

2.3.1 Absolute (not relative) time shall be recorded.

NOTE: For example, Figure 1 below gives a sample plot depicting the combined errors versus applied load.

2.3.2 When reporting values for individual test data, the data should be truncated to two significant digits to the right of the decimal place and reported in load cell verification intervals, *v*.

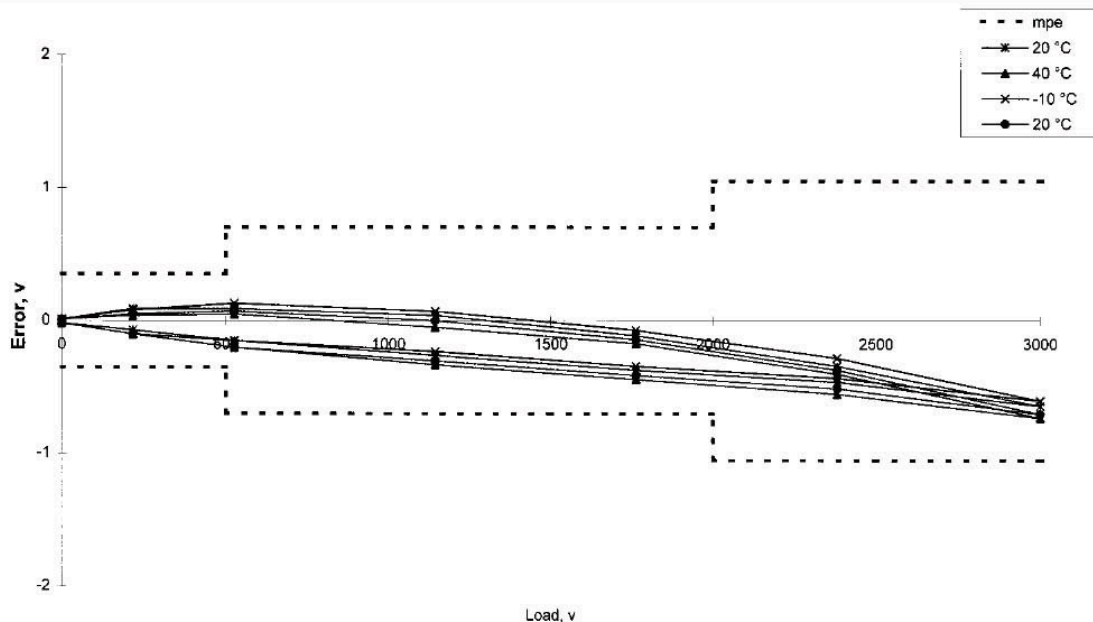

Figure 1 — Example of an error envelope

2.4 Formula signs and list of symbols

Symbol	Description	Reference
$C_C(t)$	creep magnitude, expressed in terms of v at time t obtained over the 30 minutes creep test.	2.1.5
$C_C(30-20)$	difference between output at $t = 30$ minutes and at $t = 20$ minutes during creep test.	2.1.5.2
C_{DR}	minimum dead load output return, expressed in terms of v	2.1.5
C_{Hmax}	humidity effect on maximum test load output, expressed in terms of v	2.1.7
C_{Hmin}	humidity effect on minimum test load output, expressed in terms of v	2.1.7
C_M	temperature effect on minimum dead load output, expressed in terms of v .	2.1.4
$C_M(v_{min})$	temperature effect on minimum dead load output, expressed in terms of v_{min} per 5 °C for class B, C and D or per 2 °C for class A.	2.1.4
C_P	barometric pressure effect, expressed in terms of v	2.1.6
$C_P(v_{min})$	barometric pressure effect, expressed in terms of mass (g, kg, t) per kPa.	2.1.6
D_{max}	maximum test load	R 60-1, 3.5.6
D_{min}	minimum test load	R 60-1, 3.5.12
DR	minimum dead load output return, expressed in mass units (g, kg, t)	R 60-1, 3.5.10
E_L	load cell error, expressed in terms of v	2.1.2
E_{max}	maximum capacity of the load cell	R 60-1, 3.5.5
E_{min}	minimum dead load of the load cell	R 60-1, 3.5.9
E_R	repeatability error, expressed in terms of v	2.1.3
f	conversion factor, number of indicated units per verification interval, v	2.1.2.4
MPE	maximum permissible error	R 60-1, 3.7.10
n	number of load cell verification intervals into which the load cell measuring range is divided	R 60-1 3.5.13
n_{LC}	maximum number of load cell verification intervals	R 60-1, 3.5.8
p_{LC}	apportionment factor	R 60-1, 3.7.2
R_i	reference indication (net test load), expressed in indication units	2.1.2.6
t_0	time $t_0 = 0$ min when the initial indication at minimum test load is measured	2.1.5
t	time over the 30 minute creep test period after the initial indication ($t_0 = 0$ min) at minimum test load	2.1.5

Symbol	Description	Reference
T_1, T_2	temperature1, temperature2	2.1.4.2
v	load cell verification interval	R 60-1, 3.5.4
v_{\min}	minimum load cell verification interval	R 60-1, 3.5.11
Y	relative v_{\min} , $Y = (E_{\max} - E_{\min}) / v_{\min}$	R 60-1, 3.5.15,
Z	relative DR, $Z = (E_{\max} - E_{\min}) / (2 \times DR)$	R 60-1, 3.5.14

2.5 Summary of formulae contained within calculation procedures

Symbol	Formula
C_C	$C_C = (\text{indication} - \text{initial indication}) / f$
$C_C (30 - 20)$	$C_C (30 - 20) = (\text{test indication at 30 minutes} - \text{test indication at 20 minutes}) / f$
C_{DR}	$C_{DR} = (\text{minimum test load indication 2} - \text{minimum test load indication 1}) / f$
$C_{H\min}$	$C_{H\min} = [(\text{indication at } D_{\min})_{\text{after}} - (\text{indication at } D_{\min})_{\text{before}}] / f$
$C_{H\max}$	$C_{H\max} = [(\text{indication at } D_{\max} - \text{indication at } D_{\min})_{\text{after}} - (\text{indication at } D_{\max} - \text{indication at } D_{\min})_{\text{before}}] / f$
C_M	$C_M = (\text{average test indication at } T_2 - \text{average indication at } T_1) / f$
C_P	$C_P = (\text{indication at } P_2 - \text{indication at } P_1) / f$
DR	$DR = (E_{\max} - E_{\min}) \times C_{DR} / n_{LC}$
E_L	$E_L = (\text{average test indication} - \text{reference indication}) / f$
E_R	$E_R = (\text{maximum indication} - \text{minimum indication}) / f$
f	$f = \text{average indication at } 0,75 \cdot (D_{\max} - D_{\min}) - \text{indication at } D_{\min} / 0,75 \cdot n$ [see Note 2]
R_i	$R_i = [(\text{test load} - D_{\min}) / (D_{\max} - D_{\min})] \times n \times f$
NOTE 1 Observe extreme caution by referring to calculation procedure for correct application of these formulae.	
NOTE 2 Use with initial 20 °C ascending load run only. Refer to R 60-2, 2.8.2.	

3 Guidance for the application of this Test Report Format

In case a prescribed test is not relevant for the type of instrument to be tested, the reason why the test is omitted shall be clearly stated in the field “Remarks” (for instance surge tests on signal lines shorter than 30 m, tests related to AC mains supply in case of an instrument only powered by batteries, or partial testing after modification of a previously tested type).

The number of the report and the page numbers shall be completed in the heading.

Page 1 of this Report Format may be replaced by a cover page by the Issuing Authority.

Enter “NA” or “/” for “the test is not applicable”.

4 The Evaluation Report

Cover page by the Issuing Authority

4.1 Authority responsible for this Report

Name	
Address	
Report number	
Application number	
Period of tests	
Date of issuing this Report	
Name and signature of the responsible person	
Stamp(s) (if applicable)	

4.2 Synopsis of the results of the examination and tests

The load cell under test fulfils ALL the applicable requirements according to OIML R 60-1	Yes	No
Remarks:		

4.3 Summary of the results of the examination and tests

To be completed by the Issuing Authority

4.3.1 Examinations

For details, refer to the tests as indicated in the last column.

General requirements	Passed	Failed	Details in R 60
Documentation			R 60-2, 2.5
Inscription and presentation of load cell information			R 60-1, 6.2

4.3.2 Performance tests (Refer to R 60-2, 2.10)

For details, refer to the tests as indicated in the last column.

Tests performed at (20 °C / X₁ °C / X₂ °C / 20 °C):

Test procedure	Passed	Failed	Details in R 60
Maximum permissible measurement errors			R 60-1, 5.3 / R 60-2, 2.10.1
Repeatability error			R 60-1, 5.4 / R 60-2, 2.10.1
Temperature effect on minimum dead load output return			R 60-1, 5.6.1.3 / R 60-2, 2.10.1
Creep test			R 60-1, 5.5.1 / R 60-2, 2.10.2
Minimum dead load output return (DR)			R 60-1, 5.5.2 / R 60-2, 2.10.3
Barometric pressure effects at ambient temperature			R 60-1, 5.6.2 / R 60-2, 2.10.4
Humidity effects (CH, SH)			R 60-1, 5.6.3 / R 60-2, 2.10.5 / 2.10.6

Additional tests performed for digital load cells:

Test procedure	Passed	Failed	Details in R 60
Warm-up time			R 60-1, 5.7.2.1 / R 60-2, 2.10.7.3
Power voltage variations			R 60-1, 5.7.2.2 / 5.7.2.3 / 5.7.2.4 / R 60-2, 2.10.7.4
Short-time power reductions			R 60-1, 5.7.2.5 / R 60-2, 2.10.7.5
Bursts (electrical fast transients)			R 60-1, 5.7.2.5 / R 60-2, 2.10.7.6
Surge			R 60-1, 5.7.2.5 / R 60-2, 2.10.7.7
Electrostatic discharge			R 60-1, 5.7.2.5 / R 60-2, 2.10.7.8
Electromagnetic susceptibility			R 60-1, 5.7.2.5 / R 60-2, 2.10.7.9
Immunity to conducted electromagnetic fields			R 60-1, 5.7.2.5 / R 60-2, 2.10.7.10
Span stability			R 60-1, 5.7.2.6 / R 60-2, 2.10.7.11
Software			R 60-1, 6.1

4.4 General information regarding the evaluation process

4.4.1 Manufacturer of the specimen

Company	
Address	
Contact information	

4.4.2 Applicant

Company		
Representative (name, telephone)		
Address		
Contact information		
Reference		
Date of application		
Application number		
Applicant authorised by the manufacturer (documented)	# Yes	# No
Statement that no concurrent application for OIML type evaluation has been made to any other OIML Issuing Authority (see Procedural Document PD-05 [29], 4.1.2 b)	# Yes	# No
Remarks:		

4.4.3 Testing laboratories involved in the tests

(This table has to be completed for each test laboratory)

Name			
Address			
Application number			
Tests by this laboratory			
Date/period of tests			
Name(s) of test engineer(s)			
Accredited by		Number:	Expires (date):
Accreditation includes R 60	# Yes	Edition: #	# No
Details of relevant peer assessment or assessment by other means			

In case tests have been performed at locations other than the address of this laboratory, give details here	
Name of the responsible person	
Date of signature	
Stamp (if applicable) and signature of the responsible person	
Remarks:	

4.5 General information concerning the load cell type

(as provided by the manufacturer prior to the evaluation)

Manufacturer's name/ trade mark	
Manufacturer's type designation (or load cell model number)	

	Unit	Range
Accuracy classes		
Maximum number of verification intervals, n_{LC}		
Maximum capacity, E_{max}	(g, kg, t)	
Minimum capacity, E_{min}	(g, kg, t)	
Minimum load cell verification interval, $v_{min} = (E_{max} - E_{min}) / Y$	(g, kg, t)	
Minimum dead load output return, $DR = 1 / 2 (E_{max} - E_{min}) / Z$	(g, kg, t)	
Rated output	(mVV ⁻¹ or counts)	
Input impedance	Ω	

4.6 Accessories, supplied with the test pattern by the applicant

Accessory	Remarks and specifications
Analogue data processing device (see OIML R 76 [1], T.2.2.3)	
Cables	
Load cell mounting hardware	

Accessory	Remarks and specifications
Load introduction elements	
Main power supply	
Battery (type, voltage)	
Indicator (see OIML R 76 [1], T.2.2.2)	
Data printer	
Other accessories:	

Further remarks concerning accessories:

4.7 Selection of sample(s) tested

4.7.1 Definition of the test pattern (supplied by the applicant for this test report)

This test report is issued for the following load cell:

Model designation	Serial number	Maximum capacity	Maximum number of load cell intervals	Minimum load cell verification interval	Minimum dead load output return
		E_{max} (g, kg, t)	n_{LC}	v_{min} (g, kg, t)	DR (g, kg, t)

4.7.2 Justification of the selection of the test sample(s)

(refer to R 60-2, 2.3, 2.4 and Annex D):

Model designation	Serial number	Justification / Remark	Test Report No. (if available)

Model designation	Serial number	Justification / Remark	Test Report No. (if available)

4.8 Adjustments and modifications made to the samples during the testing:

Justification of the selection of the test sample(s) (refer to R 60-2, 2.3):

Model designation	Serial number	Adjustments and modifications made to the samples	Test Report No. (if available)

Further information concerning adjustments:

4.9 Additional information concerning the type

4.9.1 General information of the load cell under test (specified by the manufacturer)

Manufacturer's name/trade mark	
Manufacturer's type designation (or load cell model number)	
Serial number	

Load cell construction (e.g. S-type, ring type, bending beam)		
Load cell material		
Sealing of strain gauge application (e.g. hermetically, potted)		
Digital load cell (Yes / no)		
Accuracy classes		
Maximum number of verification intervals, n_{LC}		
Maximum capacity, E_{max}	(g, kg, t)	
Minimum capacity, E_{min}	(g, kg, t)	
Minimum load cell verification interval, $v_{min} = (E_{max} - E_{min}) / Y$	(g, kg, t)	
Minimum dead load output return, $DR = \frac{1}{2} (E_{max} - E_{min}) / Z$	(g, kg, t)	
Rated output	(mVV ⁻¹ or counts)	
Input impedance ^a	Ω	
Cable connection ^a		4-wire / 6-wire
Cable length ^b	m	
^a mandatory for strain gauge load cells ^b mandatory for strain gauge load cells with 4-wire connection		

Additional information concerning the type (connection equipment, interfaces, etc.):

4.9.2 Additional information for the performance tests

(Refer to R 60-1, 6.2.2, 6.2.3, and 6.2.4)

Accuracy class # A # B # C # D
Working temperature (if other than -10 °C to +40 °C): Upper _____ °C, Lower _____ °C
Humidity symbol # NH # SH # CH or no marking

Loading designation: (refer to R 60-1, 6.2.4.2) Tension Compression Universal Beam (shear) Beam (bending)	
Minimum dead load as: $E_{\min} =$	
Safe load limit as: $E_{\lim} =$	
Excitation voltage: # AC # DC	
Value of the apportionment factor, p_{LC} , if not equal to 0.7	

4.9.3 Additional information of the test pattern for digital load cells

Power voltage: # AC # DC	
Interfaces:	
Output signal:	
Software identification:	
Value of the apportionment factor, p_{LC} , if not equal to 0.7	

4.9.4 Relevant photographs taken during the examinations and tests

--

4.9.5 Documentation supplied with the test pattern by the applicant

Name of the document	Content	Version No. / date of issue

4.9.6 Inscriptions and presentations of load cell information

(according to manufacturer statement, refer to R 60-1, 6.2)

R 60-1 reference	Information	On the load cell	Accompanying document	In the data sheet
6.2.1 / 6.2.2	Name or trademark of manufacturer			
6.2.1 / 6.2.2	Manufacturer's own designation or load cell model			
6.2.1	Serial number			<i>Not applicable</i>
6.2.1	Year of production			<i>Not applicable</i>
6.2.2 / 6.2.4.1	Accuracy class(es) and their symbols			
6.2.4.5	Maximum number of load cell verification intervals, n_{LC}			
6.2.2 / 6.2.4.2	Type of load			
6.2.2 / 6.2.4.3	Working temperature designation			
6.2.2 / 6.2.4.4	Humidity symbol "NH"			
6.2.2 / 6.2.4.4	Humidity symbol "SH"			
6.2.2 / 6.2.4.4	No humidity symbol or "CH"			
6.2.2	Minimum dead load, E_{min}^a			
6.2.1 / 6.2.2	Maximum capacity, E_{max}^a			
6.2.2	Safe load limit, E_{lim}^a			
6.2.2	Minimum load cell verification interval (v_{min}) ^a			
6.2.3, a	Relative v_{min} (Y)			
6.2.3, b	Minimum dead load output return DR ^a			
6.2.3, b	Relative DR (Z)			
6.2.2, 1	Rated output			
6.2.2, 1	Excitation voltage			
6.2.2, 1	Input impedance			
6.2.2, 1	Cable connection ^b			
6.2.2, 1	Cable length ^c			

4.9.8 Relevant photographs / documentation of the model range:

--

4.9.9 Definition of load cell families / construction

(This table is to be completed by the manufacturer for each load cell family within the model range)

Type / Model designation	Specification	OIML R 60-1	Remark
	Application of load	3.2.1	<i>(e.g. tension / compression)</i>
	Load cell construction	3.3	<i>(e.g. bending beam)</i>
	Material or combination of materials	3.4.2	
	Shape	3.4.2	See R 60-2, 6.2.1
	Design of measuring technique	3.3.1	<i>(e.g. strain gauge bonded to metal)</i>
	Sealing of strain gauges	3.4.2	
	Mounting method	Annex E	
	Load transmission	Annex E	See R 60-3, 4.9.1
	Output rating	3.4.2	
	Supply voltage	3.4.2	
	Input impedance	3.4.2	
	Cable connection	3.4.2	
	Cable length ^a	3.4.2	

^a mandatory for strain gauge load cells with 4-wire connection

Further remarks concerning the definition of load cell families / construction *(see table above)*

4.9.10 Load cell dimensions within the load cell family

Pictures / Drawings of the load cell dimensions of the load cell family

4.9.11 Recommended load transmissions of the manufacturer

Pictures / Drawings of the recommended load transmissions

4.9.12 Results of previous tests that were taken into account

Model designation	Serial number	Justification / Remark	Test Report No. (if available)

4.10 Information concerning the test equipment used for the tests

(including details of simulations and the way uncertainties are taken into account, including the level of “risk.” For instance, 95 % or $k = 2$)

The following tables have to be completed for each individual piece of test equipment used for the tests.

General information:

For each of the following pieces of test equipment, indicate for which of the following test procedures the test equipment is used:

R 60 reference	Test procedure
R 60-2, 2.10.1	Measurement error, repeatability error and temperature effect on minimum dead load output
R 60-2, 2.10.2	Determination of creep error
R 60-2, 2.10.3	Minimum dead load output return (DR)
R 60-2, 2.10.4	Barometric pressure effects (atmospheric pressure)
R 60-2, 2.10.5	Humidity effects for load cells marked with CH or no marked
R 60-2, 2.10.6	Humidity effects for load cells marked SH
R 60-2, 2.10.7	Additional tests for digital load cells

EXAMPLE:

A piece of test equipment is used for determination of the measurement error (R 60-2, 2.10.1), the creep error (R 60-2, 2.10.2), the minimum dead load output return (R 60-2, 2.10.3) and humidity effect marked with SH (R 60-2, 2.10.6):

R 60-2 reference	2.10.1	2.10.2	2.10.3	2.10.4	2.10.5	2.10.5	2.10.6	2.10.7
Used for								

4.10.1 Force generating system (if a force generating system or force generating machine is used)

	Description	Remark
Designation		
Type		
Manufacturer		
Identification number		
Load range		
Load steps		
Unit		
Preload		
Rel. uncertainty ($k = 2$)		
Last calibration		

	Description	Remark
Certificate No. / report No.		
Recalibration interval		

The force generating system is used for the following test procedures:

R 60-2 reference	2.10.1	2.10.2	2.10.3	2.10.4	2.10.5	2.10.5	2.10.6	2.10.7
Used for								

Remarks / picture of the force generating system:

4.10.2 Weights

(if the load cell is tested manually with weights)

Number / identification	Weight (g, kg, t)	Class ^a / rel. uncertainty ($k = 2$)	Last calibration	Recalibration interval	Certificate No. / report No.
^a according to OIML R 111					

The weights are used for the following test procedures:

R 60-2 reference	2.10.1	2.10.2	2.10.3	2.10.4	2.10.5	2.10.5	2.10.6	2.10.7
------------------	--------	--------	--------	--------	--------	--------	--------	--------

Used for								
----------	--	--	--	--	--	--	--	--

Remarks / picture of the weights:

4.10.3 Temperature chamber (without humidity control)

	Description	Remark
Designation		
Type		
Manufacturer		
Identification number		
Height × width × length dimension		
Temperature range		
Temperature stability		
Humidity range		
Humidity stability		
Rel. uncertainty ($k = 2$)		
Last calibration		
Certificate No. / report No.		
Recalibration interval		

The climate chamber is used for the following test procedures:

R 60-2 reference	2.10.1	2.10.2	2.10.3	2.10.4	2.10.5	2.10.5	2.10.6	2.10.7
Used for								

Remarks / picture of the temperature chamber:

4.10.4 Climate chamber (with temperature and humidity control)

	Description	Remark
Designation		
Type		
Manufacturer		
Identification number		
height × width × length dimension		
Temperature range		
Temperature stability		
Humidity range		
Humidity stability		
Rel. uncertainty ($k = 2$)		
Last calibration		
Certificate No. / report No.		
Recalibration interval		

The climate chamber is used for the following test procedures:

R 60-2 reference	2.10.1	2.10.2	2.10.3	2.10.4	2.10.5	2.10.5	2.10.6	2.10.7
Used for								

Remarks / picture of the climate chamber:

4.10.5 Indicator / Indicating instrument

(for testing analogue load cells)

	Description	Remark
Designation		
Type		
Manufacturer		
Identification / Serial number		
Measurement range		
Rel. uncertainty ($k = 2$)		
Last calibration		
Certificate No. / report No.		
Recalibration interval		

Settings of the indicator / indicating instrument used for the tests

	Description	Remark
Measurement range		
Supply voltage (AC/DC)		
Filter settings		
Cable connections		

The indicator / indicating instrument is used for the following test procedures:

R 60-2 reference	2.10.1	2.10.2	2.10.3	2.10.4	2.10.5	2.10.5	2.10.6	2.10.7
Used for								

Remarks / picture of the indicator / indicating instrument:

4.10.6 Terminal / Digital data processing device

(for testing digital load cells)

	Description	Remark
Designation		
Type		
Manufacturer		
Identification / Serial number		
Measurement range		
Last calibration		
Certificate No. / report No.		
Recalibration interval		

Settings of the indicator / indicating instrument used for the tests

	Description	Remark
Measurement range		
Supply voltage (AC/DC)		
Filter settings		
Cable connections		

The terminal / digital data processing device is used for the following test procedures:

R 60-2 reference	2.10.1	2.10.2	2.10.3	2.10.4	2.10.5	2.10.5	2.10.6	2.10.7
Used for								

Remarks / picture of the terminal / digital data processing device:

4.10.7 Barometric pressure meter

	Description	Remark
Type		
Manufacturer		
Identification / Serial number		
Measurement range		
Rel. uncertainty ($k = 2$)		
Last calibration		
Certificate No. / report No.		
Recalibration interval		

The barometric pressure meter is used for the following test procedures:

R 60-2 reference	2.10.1	2.10.2	2.10.3	2.10.4	2.10.5	2.10.5	2.10.6	2.10.7
Used for								

4.10.8 Thermometer

	Description	Remark
Type		
Manufacturer		
Identification / Serial number		
Measurement range		
Rel. uncertainty ($k = 2$)		

	Description	Remark
Last calibration		
Certificate No. / report No.		
Recalibration interval		

The thermometer is used for the following test procedures:

R 60-2 reference	2.10.1	2.10.2	2.10.3	2.10.4	2.10.5	2.10.5	2.10.6	2.10.7
Used for								

4.10.9 Moisture analyser

	Description	Remark
Type		
Manufacturer		
Identification / Serial number		
Measurement range		
Rel. uncertainty ($k = 2$)		
Last calibration		
Certificate No. / report No.		
Recalibration interval		

The moisture analyser is used for the following test procedures

R 60-2 reference	2.10.1	2.10.2	2.10.3	2.10.4	2.10.5	2.10.5	2.10.6	2.10.7
Used for								

4.10.10 Additional test equipment

(e.g. burst generator for testing of digital load cells)

	Description	Remark
Test equipment		
Type		

	Description	Remark
Manufacturer		
Identification / Serial number		
Measurement range		
Rel. uncertainty ($k = 2$)		
Last calibration		
Certificate No. / report No.		
Recalibration interval		

The equipment is used for the following test procedures:

R 60-2 reference	2.10.1	2.10.2	2.10.3	2.10.4	2.10.5	2.10.5	2.10.6	2.10.7
Used for								

4.10.11 Remarks (settings, pictures, further information)

5 Examination

(To be completed by the Evaluating Authority)

5.1 Marking requirements (R 60-1, 6.2)

5.1.1 Mandatory markings on the load cell (R 60-1, 6.2.1)

R 60-1 reference	Information	Fulfil requirements	
		Yes	No
6.2.1	Name or trademark of manufacturer		
6.2.1	Manufacturer's own designation or load cell model		

R 60-1 reference	Information	Fulfils requirements	
		Yes	No
6.2.1	Serial number		
6.2.1	Maximum capacity, E_{max}^a		
6.2.1	Year of production		
6.2.1	Type approval mark (if applicable)		

^a In units of (g, kg, t)

5.1.2 Mandatory markings on the load cell or an accompanying document

(R 60-1, 6.2.2)

R 60-1 reference	Mandatory information	On load cell	In document	Fulfils requirements	
				Yes	No
6.2.4.1	Accuracy classes and their symbols				
6.2.4.5	Maximum number of load cell verification intervals, n_{LC}				
6.2.4.2	Loading designation (if necessary)				
6.2.4.3	Working temperature designation				
6.2.4.4	Humidity symbol “NH”				
6.2.4.4	Humidity symbol “SH”				
6.2.2	Minimum dead load, E_{min}				
6.2.2	Safe load limit, E_{lim}				
5.1.3, 6.2.2	Minimum load cell verification interval (v_{min})				
6.2.2	Other pertinent conditions				
3.7.2, 5.3.2	Apportionment factor, p_{LC} (if not equal to 0.7)				
5.1.6	Standard classification				
5.1.7	Multiple classifications				

5.1.3 Non-mandatory, additional information (R 60-1, 6.2.3)

R 60-1 reference	Mandatory information	On load cell	In document	Fulfil requirements	
				Yes	No
5.6.3.1	Humidity symbol “CH”				
3.5.15	Relative v_{\min} , Y				
3.5.14	Relative DR, Z				

5.2 Suitability for testing (R 60-2, 2.3, 2.4)

Date:	Observer:	Serial number:	
		Fulfil requirements	
		Yes	No
Remarks			
Passed # Yes # No			

5.3 Software (if present) (R 60-1, 6.1)

Date:	Observer:	Serial number:
Version of software:	Identification code:	
	Yes	No
Software protected by sealing		
Automatic change of identification code		
Fixed version number		

Remarks:
Passed # Yes # No

5.4 Documentation for type approval (R 60-2, 2.5)

	Yes	No	Remarks
a) Description of the general principle of measurement (R 60-2, 2.5, a)			
b) List and characteristics of essential components + details			
c) Mechanical drawings (R 60-2, 2.5, b)			
d) Electric/electronic diagrams (R 60-2, 2.5, c)			
e) Installation requirements (R 60-2, 2.5, d)			
f) Sealing plan			
g) Panel layout			
h) General information of the software (R 60-2, 2.5, g)			For details, see R 60-1, 6.1
a) Operating instructions (R 60-2, 2.5, e)			
j) Information supporting the manufacturer's assumption of compliance (R 60-2, 2.5, f)			
Other relevant information pertaining to identification of the instrument, diagrams, results of previous tests, etc. : (attach photograph(s) and/or outline-drawing(s) here if available):			
Remarks:			
Passed			# Yes # No

6 Performance tests

6.1 Results of the performance tests

Clause R 60-1/2	Performance tests	Temperature in °C	report page No.	Maximum error in v	Passed	Failed	Remark
R 60-1, 5.3 / R 60-2, 2.10.1	Load cell errors (E_L) (see R 60-3, 2.1.2)						
R 60-1, 5.4 / R 60-2, 2.10.1	Repeatability errors (E_R) (see R 60-3, 2.1.3)						
R 60-1, 5.5.1 / R 60-2, 2.10.2	Creep ($C_C(t)$) (see R 60-3, 2.1.5)						
R 60-1, 5.5.1 / R 60-2, 2.10.2	Creep ($C_C(30-20)$) (see R 60-3, 2.1.5.2)						
R 60-1, 5.5.2 / R 60-2, 2.10.3	Minimum dead load output return (C_{DR}) (see R 60-3, 2.1.5.4)						(See Note 1) DR =
							(See Note 1) DR =
							(See Note 1) DR =
							(See Note 1) DR =
R 60-1, 5.6.3.1 / R 60-2, 2.10.5	Humidity effects (CH_{min}) (CH or no mark) (see R 60-3, 2.1.7.1)						
R 60-1, 5.6.3.1 / R 60-2, 2.10.5	Humidity effects (CH_{max}) (CH or no mark) (see R 60-3, 2.1.7)						
R 60-1, 5.6.3.2 / R 60-2, 2.10.6	Humidity effects (SH) (see R 60-3, 2.1.8)						
R 60-1, 5.6.1.3 / R 60-2, 2.10.1	Temperature effects on minimum dead load output (C_M) (see R 60-3, 2.1.4)			(See Note 2)			
R 60-1, 5.6.2 / R 60-2, 2.10.4	Barometric pressure effects ($C_P(v_{min})$) (see R 60-3, 2.1.6)			(See Note 2)			
NOTE 1 DR is the minimum dead load output return in units of (g, kg, t) and determined according to R 60-3, 2.1.5.8							
NOTE 2 Maximum error in unit v_{min}							

Remarks:

6.1.1 Results of the Performance tests for digital load cells

Clause R 60-1/2	Performance tests	Temperature in °C	report page No.	Maximum error in v	Passed	Failed	Remark
R 60-1, 5.7.2.1 / R 60-2, 2.10.7.3	Warm-up time (see R 60-3, 2.2.1)						
R 60-1, 5.7.2 / R 60-2, 2.10.7.4	Power voltage variations (see R 60-3, 2.2.2)						
R 60-1, 5.7.2.5 / R 60-2, 2.10.7.5	Short time power reductions (see R 60-3, 2.2.3)						
R 60-1, 5.7.2.5 / R 60-2, 2.10.7.6	Bursts (electrical fast transients) (see R 60-3, 2.2.4)						
R 60-1, 5.7.2.5 / R 60-2, 2.10.7.7	Surge (see R 60-3, 2.2.5)						
R 60-1, 5.7.2.5 / R 60-2, 2.10.7.8	Electrostatic discharge (see R 60-3, 2.2.6)						
R 60-1, 5.7.2.5 / R 60-2, 2.10.7.9	Electromagnetic susceptibility (see R 60-3, 2.2.7)						
R 60-1, 5.7.2.5 / R 60-2, 2.10.7.10	Immunity to conducted electromagnetic fields (see R 60-3, 2.2.8)						
R 60-1, 5.7.2.6 / R 60-2, 2.10.7.11	Span stability (see R 60-3, 2.2.9)						

Remarks:

6.2 Initial tests and general notes concerning performance tests

(To be completed or under the responsibility of the Evaluating Authority)

6.2.1 Units

Unit (e.g. counts, digits, g, kg, t) in which the measurement result is displayed.

R 60-2 reference	Test procedure	Unit
2.10.1	Measurement error, repeatability error and temperature effect on minimum dead load output	
2.10.2	Determination of creep error	
2.10.3	Minimum dead load output return (DR)	
2.10.4	Barometric pressure effects (Atmospheric pressure)	
2.10.5	Humidity effects for load cells marked with CH or no marked	
2.10.6	Humidity effects for load cells marked SH	
2.10.7	Additional tests for analogue-active cells	

6.2.2 Measurement range (R 60-1, 5.2, 5.5.2)

Test procedure (R 60-2 reference)	D_{\max}	D_{\min}	Conversion factor, f [indication/ v] (see R 60-3, 2.1.2.4)	Fulfil requirements	
				Yes	No
2.10.1					
2.10.2					
2.10.3					
2.10.4					
2.10.5					
2.10.6					
2.10.7					
Passed	#Yes			#No	

6.2.3 Conditions

(see R 60-2, 2.8.1)

(To ensure that these requirements are met, the calculations should be carried out using lower n values than the n_{LC} specified. The calculations made do not include the application of 2.8.1).

Check that

$$v_{\min} \leq \frac{D_{\max} - D_{\min}}{n}$$

It should be sufficient to carry out the calculations with $n = n_{LC}$, $n_{\max} - 500$ and $n = n_{LC} - 1\,000$ if applicable.

Test procedure (R 60-2 reference)	D_{\min}	D_{\max}	n_{LC}	Is the requirement $v_{\min} \leq \frac{D_{\max} - D_{\min}}{n}$ fulfilled with						
				n_{LC}		$n_{LC} - 500$		$n_{LC} - 1\,000$		
				Yes	No	Yes	No	Yes	No	
2.10.1										
2.10.2										
2.10.3										
2.10.4										
2.10.5										
2.10.6										
2.10.7										

Passed # Yes # No

6.2.4 Input impedance

Measure the input impedance and compare the result with the input impedance in OIML R 60-3, 4.5.

6.3 Load test data (Load cell error E_L) 3 runs

Ref.: R 60-2, 2.10.1.1 to 2.10.1.11. Complete one sheet for each test temperature, one for each humidity (SH) test in 2.10.6, and when applicable, one for each electronics power voltage in 2.10.7.4.

Application no.: _____

Load cell model: _____

Serial no.: _____

E_{\max} : _____

n_{LC} : _____

v_{\min} : _____

p_{LC} : _____ DR: _____

Force-generating system: _____

Indicating instrument: _____

Evaluator: _____

	At start	At end	
Date:			
Temperature:			°C
Relative humidity:			%
Barometric pressure:			kPa
Indicator temperature:			°C

Electronics power voltage (when applicable): _____

Table 1 — (3 runs)

Test load (units)	Run no. 1		Run no. 2		Run no. 3		Average indication (counts)	Repeatability error (counts)
	Indication (counts)	Time (hh mm ss)	Indication (counts)	Time (hh mm ss)	Indication (counts)	Time (hh mm ss)		
0								
0								
0								
0								
0							*	

6.4 Load test data (Load cell error E_L) 5 runs

R 60-2, 2.10.1.1 to 2.10.1.11. Complete one sheet for each test temperature, one for each humidity (SH) test in 2.10.6, and when applicable, one for each electronics power voltage in 2.10.7.4.

Application no.: _____

Load cell model: _____

Serial no.: _____

E_{max} : _____

n_{LC} : _____

v_{min} : _____

p_{LC} : _____ DR: _____

Force-generating system: _____

Indicating instrument: _____

Evaluator: _____

	At start	At end	
Date:			
Temperature:			°C
Relative humidity:			%
Barometric pressure:			kPa

Indicator temperature:			°C
------------------------	--	--	----

Electronics power voltage (when applicable): _____

Table 2 — (5 runs)

Test load (units)	Run no. 1		Run no. 2		Run no. 3		Run no. 4		Run no. 5		Average indication (counts)	Repeatability error (counts)
	Indication (counts)	Time (hh mm ss)	Indication (counts)	Time (hh mm ss)	Indication (counts)	Time (hh mm ss)	Indication (counts)	Time (hh mm ss)	Indication (counts)	Time (hh mm ss)		
0												
0												
0												
0												
0											*	

6.5 Load cell errors (E_L) calculation

R 60-1, 5.3.1

R 60-2, 2.10.1.12 to 2.10.1.14

R 60-3, 2.1.2.2

Application no.: _____

Load cell model: _____

Serial no.: _____

E_{max} : _____

n_{LC} : _____

v_{min} : _____

p_{LC} : _____ DR: _____

Force-generating system: _____

Indicating instrument: _____

Evaluator: _____

	At start	At end	
Date:			
Temperature:			°C
Relative humidity:			%
Barometric pressure:			kPa
Indicator temperature:			°C

Conversion factor, f : _____

75 % test load (g, kg, t): _____

Reference indication at 75 % test load: _____

Table 3

Test load (units)	Reference indication (counts) °C (20 °C)	 °C (T_1 °C)	 °C (T_2 °C)	 °C (20 °C)		MPE (v)
		Indications (counts)	Error (E_L) (v)	Indication (counts)	Error (E_L) (v)	Indication (counts)	Error (E_L) (v)	Indication (counts)	Error (E_L) (v)	
0	0	0		0		0		0		

(continued)

Test load (units)	Reference indication (counts) °C (20 °C)	 °C (T_1 °C)	 °C (T_2 °C)	 °C (20 °C)		MPE (v)
		Indications (counts)	Error (E_L) (v)	Indication (counts)	Error (E_L) (v)	Indication (counts)	Error (E_L) (v)	Indication (counts)	Error (E_L) (v)	

Minimum test load, D_{min} : _____ PASS: FAIL:

- NOTE:
- a) Load/reference indications: if a 75 % load point was not obtained, a straight line interpolation between the adjacent higher and lower load point indications is used (see R 60-1, 5.3.1 and calculation procedures in R 60-3, 2.1.2.2).
 - b) Error, E_L : the difference between the test indication and the reference indication divided by the conversion factor, f .
 - c) Test load values are values above minimum test load, D_{min} .

6.6 Repeatability errors (E_R) calculation

R 60-1, 5.4
 R 60-2, 2.10.1.15
 R 60-3, 2.1.3

Application no.: _____

Load cell model: _____

Serial no.: _____

NOTE: Error, E_R : the maximum difference between the three test indications divided by the conversion factor, f (classes C and D) or the maximum difference between the five test indications divided by the conversion factor, f (classes A and B).

6.7 Temperature effects on minimum dead load output (MDLO)

R 60-1, 5.5.2
 R 60-2, 2.10.1.16
 R 60-3, 2.1.4

Application no.: _____
 Load cell model: _____
 Serial no.: _____
 E_{max} : _____
 n_{LC} : _____
 v_{min} : _____
 p_{LC} : _____ DR: _____
 Force-generating system: _____
 Indicating instrument: _____
 Evaluator: _____
 Conversion factor, f : _____

Table 5

Temperature (°C)	Indication ()	Change (v)	Change (v_{min}/\dots °C)	mpc (v_{min}/\dots °C)
				p_{LC}
				p_{LC}
				p_{LC}

PASS: # FAIL: #

- NOTE:**
- a) MDLO: minimum dead load output.
 - b) Indication: the average initial minimum test load indication obtained from Table 1.
 - c) The maximum permissible change (mpc) allowed is: ($v_{min}/5$ °C) for classes B, C, and D; ($v_{min}/2$ °C) for class A.
 - d) Change, $C_M(v)$: the difference between the observed indications, and the indications at the prior temperature, divided by the conversion factor, f .

6.8 Creep (C_C) and DR (C_{DR})

R 60-1, 5.5.1, 5.5.2

R 60-2, 2.10.2, 2.10.3. Complete one sheet for each test temperature.

Application no.: _____

Load cell model: _____

Serial no.: _____

E_{max} : _____

n_{LC} : _____

v_{min} : _____

p_{LC} : _____ DR: _____

Force-generating system: _____

Indicating instrument: _____

Evaluator: _____

	At start	At end	
Date:			
Temperature:			°C
Relative humidity:			%
Barometric pressure:			kPa
Indicator temperature:			°C

Conversion factor, f : _____

Table 6

Creep						DR							
Test load	Original		Barom. Press.	Change of		mpc	Test load	Original		Barom. Press.	Change of		mpc
	Indication	Time		Indication	Time			Indication	Time		Indication	Time	
	counts	hh: mm: ss	kPa	v	mm: ss	v		counts	hh: mm: ss	kPa	v	mm: ss	v
D_{min}													
D_{max}													

MPE for DR (v): _____	DR within manuf. Specified DR requirements: PASS: <input type="checkbox"/> FAIL: <input type="checkbox"/>
---------------------------	---

NOTE:

- a) Change (v) for creep: the observed indication minus the initial “load” indication (***) divided by the conversion factor, f .
- b) Determine the difference between the reading obtained at 20 minutes and the reading obtained at 30 minutes (see 5.5.1).
- c) Change (v) for DR: the initial indication (***) minus the initial “no load” indication (*) divided by the conversion factor, f .
- d) Absolute (not relative) time shall be recorded.

6.9 Barometric pressure effects (C_p)

R 60-1, 5.6.2
 R 60-2, 2.7.3.8, 2.10.4
 R 60-3, 2.1.6

Complete one sheet for each test temperature.

Application no.: _____

Load cell model: _____

Serial no.: _____

E_{max} : _____ E_{min} : _____

n_{LC} : _____ p_{LC} : _____

Y: _____ Z: _____

v_{min} : _____ DR: _____

Force-generating system: _____

Test load: D_{max} : _____ D_{min} : _____

Indicating instrument: _____

Evaluator: _____

	At start	At end	
Date:			
Temperature:			°C
Relative humidity:			%
Barometric pressure:			kPa
Indicator temperature:			°C

Conversion factor, f : _____

Table 7

Pressure (kPa)	Indication (counts)	Time hh:mm	Change (v)	Change (v_{\min} / kPa)	mpe (v_{\min} / kPa)
			0	0	0
					1

PASS: # FAIL: #

6.10 Humidity effects

6.10.1 Humidity effects (CH or no mark)

R 60-1, 5.6.3
 60-2, 2.7.3.9, 2.10.5
 R 60-3, 2.1.7

6.10.1.1 Form 6.10.1.(a): Humidity effects summary (CH or no mark)

Application no.: _____

Load cell model: _____

Serial no.: _____

E_{\max} : _____ E_{\min} : _____

n_{LC} : _____ p_{LC} : _____

Y: _____ Z: _____

v_{\min} : _____ DR: _____

Force-generating system: _____

Test load: D_{\max} : _____ D_{\min} : _____

Indicating instrument: _____

Evaluator: _____

	At start	At end	
Date:			
Temperature:			°C
Relative humidity:			%
Barometric pressure:			kPa
Indicator temperature:			°C

(‡) Indications at maximum test load c)

(*) Average, see R 60-1, 5.6.3 and R 60-3, 2.1.7

Change (*), C_{Hmax} : PASS: # FAIL: #

NOTE:

- a) This test is not necessary if the load cell is marked NH or SH.
- b) Change (v): the difference between the indication after and before humidity exposure divided by the conversion factor, f .
- c) Use five test runs for Class A and B; use 3 test runs for Class C and D.
- d) Absolute (not relative) time shall be recorded.
- e) For family certification this test is not necessary, if a pattern with a smaller capacity and the same or better metrological characteristics has passed this test.

6.10.2 Form 6.10.1.(b): Load test data (E_D) — 3 runs

R 60-2, 2.10.1.1-2.10.1.11. Complete this form if the measurement error is determined **before** the humidity test (CH) is carried out (not mandatory)

Application no.: _____

Load cell model: _____

Serial no.: _____

E_{max} : _____ E_{min} : _____

n_{LC} : _____ p_{LC} : _____

Y: _____ Z: _____

v_{min} : _____ DR: _____

Force-generating system: _____

Test load: D_{max} : _____ D_{min} : _____

Indicating instrument: _____

Evaluator: _____

	At start	At end	
Date:			
Temperature:			°C
Relative humidity:			%
Barometric pressure:			kPa
Indicator temperature:			°C

6.10.2.1 Form 6.10.1.(c): Load test data (E_L)—3 runs

R 60-2, 2.10.1.1-2.10.1.11. Complete this form if the measurement error is determined **after** the humidity test (CH) is carried out (not mandatory)

Application no.: _____

Load cell model: _____

Serial no.: _____

E_{max} : _____ E_{min} : _____

n_{LC} : _____ p_{LC} : _____

Y: _____ Z: _____

v_{min} : _____ DR: _____

Force-generating system: _____

Test load: D_{max} : _____ D_{min} : _____

Indicating instrument: _____

Evaluator: _____

	At start	At end	
Date:			
Temperature:			°C
Relative humidity:			%
Barometric pressure:			kPa
Indicator temperature:			°C

Electronics power voltage (when applicable): _____

Table 10 — (3 runs)

Test load (unit)	Run no. 1		Run no. 2		Run no. 3		Average indication counts	Repeatability error counts
	Indication counts	Time hh: mm:ss	Indication counts	Time hh: mm:ss	Indication counts	Time hh: mm:ss		

Table 10 (continued)

Test load (unit)	Run no. 1		Run no. 2		Run no. 3		Average indication counts	Repeatability error counts
	Indication counts	Time hh:mm:ss	Indication counts	Time hh:mm:ss	Indication counts	Time hh:mm:ss		

NOTE * Average initial minimum test load indication Absolute (not relative) time shall be recorded

6.10.3 Form 6.10.1.(d): Load test data (E_L)—5 runs

R 60-2, 2.10.1.1-2.10.1.11. Complete this form if the measurement error is determined **before** the humidity test (CH) is carried out (not mandatory)

Application no.: _____

Load cell model: _____

Serial no.: _____

E_{max} : _____

n_{LC} : _____

v_{min} : _____

p_{LC} : _____ DR: _____

Force-generating system: _____

Indicating instrument: _____

Evaluator: _____

	At start	At end	
Date:			
Temperature:			°C
Relative humidity:			%
Barometric pressure:			kPa
Indicator temperature:			°C

Application no.: _____

Load cell model: _____

Serial no.: _____

E_{max} : _____ E_{min} : _____

n_{LC} : _____ p_{LC} : _____

Y: _____ Z: _____

v_{min} : _____ DR: _____

Force-generating system: _____

Test load: D_{max} : _____ D_{min} : _____

Indicating instrument: _____

Evaluator: _____

	At start	At end	
Date:			
Temperature:			°C
Relative humidity:			%
Barometric pressure:			kPa
Indicator temperature:			°C

Electronics power voltage (when applicable): _____

6.10.5 Humidity effects (SH)

6.10.5.1 Form 6.10.2 Humidity effects (SH) summary

R 60-1, 5.6.3.2

R 60-2, 2.7.3.9, 2.10.6

R 60-3, 2.1.8

Application no.: _____

Load cell model: _____

Serial no.: _____

E_{max} : _____

n_{LC} : _____

v_{min} : _____

p_{LC} : _____ DR: _____

Force-generating system: _____

Indicating instrument: _____

Evaluator: _____

	At start	At end	
Date:			
Conditioning period:			
Reference temperature:			°C
High temperature:			°C
Reference relative humidity:			%
High relative humidity:			%

Conversion factor, f : _____

Page of load test before humidity test: _____

Page of load test during humidity test: _____

Page of load test after humidity test: _____

For summary of SH-humidity load test errors: use form 6.3 (3 runs) or 6.4 (5 runs) as appropriate to record individual test results.

6.11 Warm-up time

6.11.1 Form 6.11 Warm-up time

R 60-1, 3.5.17

R 60-2, 2.10.7.3

R 60-3, 2.2.1

Application no.: _____

Load cell model: _____

Serial no.: _____

E_{\max} : _____ E_{\min} : _____

n_{LC} : _____ p_{LC} : _____

Y: _____ Z: _____

v_{\min} : _____ DR: _____

Force-generating system: _____

Test load: D_{\max} : _____ D_{\min} : _____

Indicating instrument: _____

Evaluator: _____

	At start	At end	
Date:			
Temperature:			°C
Relative humidity:			%
Barometric pressure:			kPa
Indicator temperature:			°C

Conversion factor, f : _____ counts/ v

Duration of disconnection before test: _____

Table 14

	Initial run		After 5 min.		After 15 min.		After 30 min.		mpc v_{\min}
	Indication (counts)	Time hh: mm: ss	Indication (counts)	Time hh: mm: ss	Indication (counts)	Time hh: mm: ss	Indication (counts)	Time hh: mm: ss	
D_{\min}									

(continued)

		Initial run		After 5 min.		After 15 min.		After 30 min.		mpc v_{\min}
		Indication (counts)	Time hh: mm: ss	Indication (counts)	Time hh: mm: ss	Indication (counts)	Time hh: mm: ss	Indication (counts)	Time hh: mm: ss	
	D_{\max}									
Span	Counts									
Span	v_{\min}									
Change	v_{\min}									

PASS: # FAIL: #

NOTE:

- Absolute (not relative) time shall be recorded.
- Span: the result of subtraction of the indication at minimum test load from the indication at maximum test load. All span errors (error at maximum test load minus the error at minimum test load) shall be within the maximum permissible error during the 30 minute test.
- The change of span must not exceed v_{\min} .
- Change: the difference between the span and the initial run span.
- Maximum permissible change, mpc: the absolute value of the maximum permissible error for the maximum test load applied.
- Exercises have to be run before disconnection.

6.12 Power voltage variation

6.12.1 Form 6.12 Power voltage variation

R 60-1, 5.7.2.2, 5.7.2.3, 5.7.2.4

R 60-2, 2.10.7.4

R 60-3, 2.2.2

Application no.: _____

Load cell model: _____

Serial no.: _____

 E_{\max} : _____ E_{\min} : _____ n_{LC} : _____ p_{LC} : _____

Y: _____ Z: _____

 v_{\min} : _____ DR: _____

Force-generating system: _____

Test load:, D_{max} : _____ D_{min} : _____

Indicating instrument: _____

Evaluator: _____

	At start	At end	
Date:			
Temperature:			°C
Relative humidity:			%
Barometric pressure:			kPa
Indicator temperature:			°C

Conversion factor, f : _____ counts/v

Main voltage: _____

AC: DC:

Table 15

Test load (units)	Preloads	
	Indication (counts)	Time hh:mm:ss
D_{min}		
D_{max}		
D_{min}		
D_{max}		
D_{min}		
D_{max}		

NOTE

- a) Reference indications: if at 75 % load point was not obtained, a straight line interpolation between the adjacent higher and lower indication is used (see 2.8.2 in R 60-2 and calculation procedures in R 60-3, 2.1.2)
- b) Error: the difference between the test indication and the reference indication divided by the conversion factor, f .
- c) The change of span must not exceed v_{min} .
- d) When a voltage range is marked, use the average value as the reference value and determine upper and lower values of applied voltage according to R 60-2, 2.10.7.4.
- e) Upper limit not applicable to battery powered load cells
- f) At lower limit, battery powered load cells shall function and be within MPE, or cease to function

		Initial run with main voltage		lower limit main voltage— 15 %		upper limit +10 %		mpc
		Indication (counts)	Time hh: mm:ss	Indication (counts)	Time hh: mm:ss	Indication (counts)	Time hh: mm:ss	
	D_{\min}							
	D_{\max}							
Span	Counts							
Span	v_{\min}							
Change	v_{\min}							

PASS: # FAIL: #

6.13 Short time power reductions

6.13.1 Form 6.13 Short time power reductions

R 60-1, 5.7.2.5

R 60-2, 2.10.7.5

R 60-3, 2.2.3

Application no.: _____

Load cell model: _____

Serial no.: _____

E_{\max} : _____

n_{LC} : _____

v_{\min} : _____

p_{LC} : _____ DR: _____

Force-generating system: _____

Indicating instrument: _____

Evaluator: _____

Date: _____

Time: _____

Temperature: _____ °C

Relative humidity: _____ %

Barometric pressure: _____ kPa

Conversion factor, f : _____

Minimum test load, D_{\min} : _____

Reference voltage range: _____ V

Table 16

Test load (g, kg, t)	Disturbance				Result			
	Amplitude (%)	Duration (cycles)	Number of disturbances	Repetition interval (v)	Indication ()	Difference ()	Significant fault $> v_{\min}$	
							No	Yes (remarks)
Without disturbance								
	0	0.5	10					
	50	1	10					

PASS: # FAIL: #

Equipment used (supply sketch if necessary):

Remarks:

NOTE: In the case of a voltage range, use the average value as the reference value.

6.14 Bursts (electrical fast transients)

6.14.1 Form 6.14.1 Bursts (electrical fast transients)—power supply lines

R 60-1, 5.7.2.5

R 60-2, 2.10.7.6

R 60-3, 2.2.4

Application no.: _____

Load cell model: _____

Serial no.: _____

E_{\max} : _____

n_{LC} : _____

v_{\min} : _____

p_{LC} : _____ DR: _____

Force-generating system: _____

Indicating instrument: _____

Evaluator: _____

Date: _____

Time: _____

Temperature: _____ °C

Relative humidity: _____ %

Barometric pressure: _____ kPa

Conversion factor, *f*: _____

Minimum test load, D_{min} : _____

Table 17 — Power supply lines: test voltage = 2 kV; duration of test = 1 minute at each polarity

Test load (g, kg, or t)	Connection			Polarity	Result			
	L to ground	N to ground	PE to ground		Indication ()	Difference (<i>v</i>)	Significant fault > v_{min}	
							No	Yes (remarks)
	without disturbance							
	x			pos				
				neg				
	without disturbance							
		x		pos				
				neg				
	without disturbance							
			x	pos				
				neg				

PASS: # FAIL: #

L = phase, N = neutral, PE = protective earth

Equipment used (supply sketch if necessary)

6.14.2 Form 6.14.2 Bursts (electrical fast transients)— I/O circuits and communications lines

R 60-1, 5.7.2.5

R 60-2, 2.10.7.6

R 60-3, 2.2.4

Application no.: _____

Load cell model: _____

Serial no.: _____

E_{max} : _____

n_{LC} : _____

v_{min} : _____

p_{LC} : _____ DR: _____

Force-generating system: _____

Indicating instrument: _____

Evaluator: _____

Date: _____

Time: _____

Temperature: _____ °C

Relative humidity: _____ %

Barometric pressure: _____ kPa

Conversion factor, f : _____

Minimum test load, D_{min} : _____

Table 18

Test load (g, kg, or t)	Cable interface	Polarity	Result			
			Indication ()	Difference (v)	Significant fault > v_{min}	
					No	Yes (remarks)
	without disturbance					
		pos				
		neg				
	without disturbance					
		pos				
		neg				
	without disturbance					
		pos				
		neg				
	without disturbance					
		pos				
		neg				

(continued)

Test load (g, kg, or t)	Cable interface	Polarity	Result			
			Indication ()	Difference (v)	Significant fault > v_{\min}	
					No	Yes (remarks)
	without disturbance					
		pos				
		neg				
	without disturbance					
		pos				
		neg				

PASS: # FAIL: #

Equipment used (supply sketch if necessary)

Remarks:

NOTE: Explain or make a sketch indicating where the clamp is located on the cable: if necessary use additional page(s).

6.15 Surges

6.15.1 Form 6.15 Surges

R 60-1, 5.7.2.5

R 60-2, 2.10.7.7

R 60-3, 2.2.5

Application no.: _____

Load cell model: _____

Serial no.: _____

 E_{\max} : _____ n_{LC} : _____ v_{\min} : _____ p_{LC} : _____ DR: _____

Force-generating system: _____

Indicating instrument: _____

Evaluator: _____

Conversion factor, f : _____

Minimum test load, D_{\min} : _____

Table 19

OIML R 60-2, [unit] #[g]; #[kg]; #[t];	Test conditions surges on signal, data and control lines				Observer's name:
	Output gained	#	using actual loads		
			Test load:		Line to line 1 kV
		#	simulating loading		Line to earth 2 kV
			using:		
	Cable:				# Symmetrical line
	Date:		Start	Stop	# Unsymmetrical line
	Time:				Specimen:
	Ambient temperature		°C	°C	f
	Relative humidity		%	%	D_{\min} [unit]
Barometric Pressure		kPa	kPa	D_{\max} [unit]	
	Cycle phase	Initial	During exposure	After	
	Load				
Time	Start				
	Stop				
Quantity [unit]	reference				
	indicated				
Error [v_{\min}]					
relative error [%] E_{ij}					
MPE [%]					
	Pass	#		#	
	Fail	#		#	
Observed faults after exposure					
Fault limit [%]				

(continued)

Line to line (N/A for balanced)		Fault/Deviation	Significant		Acts on fault	
↑ ■	↓ ■		Yes	No	Yes	No
3x			#	#	#	#
	3x		#	#	#	#
Line to earth						
3x			#	#	#	#
	3x		#	#	#	#
Observations						
Result			Pass	#	Fail	#

6.16 Electrostatic discharge

6.16.1 Form 6.16.1 Electrostatic discharge — direct application

R 60-1, 5.7.2.5

R 60-2, 2.10.7.8

R 60-3, 2.2.6

Application no.: _____

Load cell model: _____

Serial no.: _____

 E_{\max} : _____ n_{LC} : _____ v_{\min} : _____ p_{LC} : _____ DR: _____

Force-generating system: _____

Indicating instrument: _____

Evaluator: _____

Date: _____

Time: _____

Temperature: _____ °C

Relative humidity: _____ %

Barometric pressure: _____ kPa

Conversion factor, f : _____

Minimum test load, D_{\min} : _____

Contact discharges

Paint penetration

Air discharges

Polarity (see Note 2):

Positive

Negative

Table 20

Test load (g, kg, t)				Result			
	Test voltage (kV)	No. of discharges ≥10	Repetition interval (s)	Indication ()	Difference (v)	Significant fault > v_{\min}	
						No	Yes (remarks)
	without disturbance						
	2						
	4						
	6						
	8 (air discharges)						

PASS: # FAIL: #

Remarks:

NOTE If the load cell fails, the test point at which this occurs shall be recorded.

I:

NOTE IEC Publication 61000-4-2 Ed 2.0 (2008-12) Consolidated edition specifies that the test be conducted with the most sensitive polarity.

6.16.2 Form 6.16.2 Electrostatic discharge — indirect application

R 60-1, 5.7.2.5

R 60-2, 2.10.7.8

R 60-3, 2.2.6

Application no.: _____

Load cell model: _____

Serial no.: _____

 E_{\max} : _____ n_{LC} : _____ v_{\min} : _____ p_{LC} : _____ DR: _____

Force-generating system: _____

Indicating instrument: _____

Evaluator: _____

Date: _____

Time: _____

Temperature: _____ °C

Relative humidity: _____ %

Barometric pressure: _____ kPa

Conversion factor, f : _____Minimum test load, D_{\min} : _____

Polarity (see Note 2):

 Positive Negative

Table 21 — Horizontal coupling plane

Test load (g, kg, t)				Result			
	Test voltage (kV)	No. of discharges ≥ 10	Repetition interval (s)	Indication ()	Difference (v)	Significant fault $> v_{\min}$	
						No	Yes (remarks)
	without disturbance						
	2						
	4						
	6						

Table 22 — Vertical coupling plane

Test load (g, kg, t)				Result			
	Test voltage (kV)	No. of discharges ≥ 10	Repetition interval (s)	Indication ()	Difference (v)	Significant fault $> v_{\min}$	
						No	Yes (remarks)
	without disturbance						
	2						
	4						
	6						

PASS: # FAIL: #

Remarks:

NOTE If the load cell fails, the test point at which this occurs shall be recorded.

1:

NOTE IEC Publication 61000-4-2 Ed. 2.0 (2008-12). Consolidated edition specifies that the test be conducted with the most sensitive polarity.

6.16.3 Form 6.16.3 Electronic discharge (continued) — specification of test points

R 60-1, 5.7.2.5

R 60-2, 2.10.7.8

R 60-3, 2.2.6

Specify test points utilised on load cell and test equipment used, e.g. by photos or sketches.

a) Direct application

Contact discharges:

Air discharges:

b) Indirect application

6.17 Electromagnetic susceptibility

6.17.1 Form 6.17.1 Electromagnetic susceptibility

R 60-1, 5.7.2.5

R 60-2, 2.10.7.9

R 60-3, 2.2.7

Application no.: _____

Load cell model: _____

Serial no.: _____

E_{max} : _____
 n_{LC} : _____
 v_{min} : _____
 p_{LC} : _____ DR: _____
 Force-generating system: _____
 Indicating instrument: _____
 Evaluator: _____
 Date: _____
 Time: _____
 Temperature: _____ °C
 Relative humidity: _____ %
 Barometric pressure: _____ kPa
 Conversion factor, f : _____
 Minimum test load, D_{min} : _____
 Rate of sweep: _____
 Test load: _____
 Test load material: _____

Table 23

Disturbance				Result			
Antenna	Frequency range (MHz)	Polarisation	Facing load cell	Indication ()	Difference (v)	Significant fault > v_{min}	
						No	Yes (remarks)
without disturbance							
		Vertical	Front				
			Right				
			Left				
			Rear				
		Horizontal	Front				
			Right				
			Left				

(continued)

Disturbance				Result			
Antenna	Frequency range (MHz)	Polarisation	Facing load cell	Indication ()	Difference (v)	Significant fault > v_{\min}	
						No	Yes (remarks)
			Rear				

PASS: # FAIL: #

Frequency range: 80 MHz⁴⁾ to 3 000 MHzField strength: 10 Vm⁻¹

Modulation: 80 % AM, 1 kHz sine wave

Remarks:

NOTE: If the load cell fails, the test point at which this occurs shall be recorded.**6.17.2 Form 6.17.2 Electromagnetic susceptibility (continued) — description of the test setup**

Describe the setup of the test and equipment, e.g. by photos or sketches:

4) The lower limit of frequency of electromagnetic field is 26 MHz for load cells without power lines or I/O ports, and for which the test for conducted electromagnetic field (R 60-2, 2.10.7.10) is not applicable.

6.18 Immunity to conducted electromagnetic fields

6.18.1 Form 6.18 Immunity to conducted electromagnetic fields

R 60-1, 5.7.2.5
 R 60-2, 2.10.7.10
 R 60-3, 2.2.8

Application no.: _____
 Load cell model: _____
 Serial no.: _____
 E_{max} : _____
 n_{LC} : _____
 v_{min} : _____
 p_{LC} : _____ DR: _____
 Force-generating system: _____
 Indicating instrument: _____
 Evaluator: _____
 Date: _____
 Time: _____
 Temperature: _____ °C
 Relative humidity: _____ %
 Barometric pressure: _____ kPa
 Conversion factor, f : _____
 Minimum test load, D_{min} : _____
 Rate of sweep: _____
 Test load: _____
 Test load material: _____

Table 24

OIML R 60-2, [unit] # [g]; # [kg]; # [t]	test conditions rf current injection		Observer's name:	
	output gained	#	using actual loads	
			Test load:	$f_l =$ MHz
		#	simulating loading	$f_h =$ MHz
		using:	RF voltage v_{emf}	

(continued)

	Cable exposed			Modulation % AM
	Date:		Start Stop	Dwell time s
	Time:			Specimen:
	Ambient temperature	°C	°C	f
	Relative humidity	%	%	D_{\min} [unit]
	Barometric pressure	kPa	kPa	D_{\max} [unit]
Frequency cycle	Cycle phase	Initial	During exposure	After
	Load			
Time	Start			
	Stop			
Quantity [unit]	reference			
	indicated			
Error [v_{\min}]				
relative error [%] E				
MPE [%]				
	Pass	#		#
	Fail	#		#
Observed faults during exposure				
Fault limit [%]			
Frequency		Fault/Deviation	Significant	Acts on fault
MHz			Yes No	Yes No
			# #	# #
			# #	# #
			# #	# #
			# #	# #
			# #	# #

(continued)

			#	#	#	#
			#	#	#	#
			#	#	#	#
			#	#	#	#
			#	#	#	#
			#	#	#	#
			#	#	#	#
			#	#	#	#
Observations						
Result			Pass	#	Fail	#

6.19 Span stability

6.19.1 Form 6.19.1 (3 runs) Span stability — measurement data for classes C and D

R 60-1, 5.7.2.6

R 60-2, 2.10.7.11

R 60-3, 2.2.9

Application no.: _____

Load cell model: _____

Serial no.: _____

E_{\max} : _____

n_{LC} : _____

v_{\min} : _____

p_{LC} : _____ DR: _____

Force-generating system: _____

Indicating instrument: _____

Evaluator: _____

Conversion factor, f : _____

Minimum test load, D_{\min} : _____

Maximum test load, D_{\max} : _____

NOTE:

- a) Span is the result of subtracting the average indication at minimum test load from the average indication at maximum test load.
- b) Absolute (not relative) time shall be recorded.

Measurement no. 1:

Test load (unit) (g, kg, t)	Run no. 1		Run no. 2		Run no. 3		Average indication ()
	Indication ()	Time	Indication ()	Time	Indication ()	Time	
						span	

Evaluator: _____ Remarks:

Date: _____

Time: _____

Temperature: _____ °C

Relative humidity: _____ %

Barometric pressure: _____ kPa

Measurement no. 2:

Test load (unit) (g, kg, t)	Run no. 1		Run no. 2		Run no. 3		Average indication ()
	Indication ()	Time	Indication ()	Time	Indication ()	Time	
						span	

Evaluator: _____ Remarks:

Date: _____

Time: _____

Temperature: _____ °C

Relative humidity: _____ %

Barometric pressure: _____ kPa

Measurement no. 3:

Test load (unit) (g, kg, t)	Run no. 1		Run no. 2		Run no. 3		Average indication ()
	Indication ()	Time	Indication ()	Time	Indication ()	Time	
						span	

Evaluator: _____ Remarks:

Date: _____

Time: _____

Temperature: _____ °C

Relative humidity: _____ %

Barometric pressure: _____ kPa

Measurement no. 4:

Test load (unit) (g, kg, t)	Run no. 1		Run no. 2		Run no. 3		Average indication ()
	Indication ()	Time	Indication ()	Time	Indication ()	Time	
						span	

Evaluator: _____ Remarks:

Date: _____

Time: _____

Temperature: _____ °C

Relative humidity: _____ %

Barometric pressure: _____ kPa

Measurement no. 5:

Test load (unit) (g, kg, t)	Run no. 1		Run no. 2		Run no. 3		Average indication ()
	Indication ()	Time	Indication ()	Time	Indication ()	Time	
						span	

Evaluator: _____ Remarks:

Date: _____

Time: _____

Temperature: _____ °C

Relative humidity: _____ %

Barometric pressure: _____ kPa

Measurement no. 6:

Test load (unit) (g, kg, t)	Run no. 1		Run no. 2		Run no. 3		Average indication ()
	Indication ()	Time	Indication ()	Time	Indication ()	Time	
						span	

Evaluator: _____ Remarks:

Date: _____

Time: _____

Temperature: _____ °C

Relative humidity: _____ %

Barometric pressure: _____ kPa

Measurement no. 7:

Test load (unit) (g, kg, t)	Run no. 1		Run no. 2		Run no. 3		Average indication ()
	Indication ()	Time	Indication ()	Time	Indication ()	Time	
						span	

Evaluator: _____ Remarks:

Date: _____

Time: _____

Temperature: _____ °C

Relative humidity: _____ %

Barometric pressure: _____ kPa

Measurement no. 8:

Test load (unit) (g, kg, t)	Run no. 1		Run no. 2		Run no. 3		Average indication ()
	Indication ()	Time	Indication ()	Time	Indication ()	Time	
						span	

Evaluator: _____ Remarks:

Date: _____

Time: _____

Temperature: _____ °C

Relative humidity: _____ %

Barometric pressure: _____ kPa

6.19.2 Form 6.19.2 (5 runs) Span stability measurement data for class B

R 60-1, 5.7.2.6

R 60-2, 2.10.7.11

R 60-3, 2.2.9

NOTE:

- a) Span is the result of subtracting the average indication at minimum test load from the average indication at maximum test load.
- b) Absolute (not relative) time shall be recorded.

Table 25 — Measurement no. 1 (5 runs)

Test load (unit) (g, kg, t)	Run no. 1		Run no. 2		Run no. 3		Run no. 4		Run no. 5		Average indication ()
	indication ()	Time	indication ()	Time	indication ()	Time	indication ()	Time	indication ()	Time	
										span	

Evaluator: _____ Remarks:

Date: _____

Time: _____

Temperature: _____ °C

Relative humidity: _____ %

Barometric pressure: _____ kPa

Table 26 — Measurement no. 2 (5 runs)

Test load (unit) (g, kg, t)	Run no. 1		Run no. 2		Run no. 3		Run no. 4		Run no. 5		Average indication ()
	indication ()	Time	indication ()	Time	indication ()	Time	indication ()	Time	indication ()	Time	
										span	

Evaluator: _____ Remarks:

Date: _____

Time: _____

Temperature: _____ °C

Relative humidity: _____ %

Barometric pressure: _____ kPa

Table 27 — Measurement no. 3 (5 runs)

Test load (unit) (g, kg, t)	Run no. 1		Run no. 2		Run no. 3		Run no. 4		Run no. 5		Average indication ()
	indication ()	Time	indication ()	Time	indication ()	Time	indication ()	Time	indication ()	Time	
										span	

Evaluator: _____ Remarks:

Date: _____

Time: _____

Temperature: _____ °C

Relative humidity: _____ %

Barometric pressure: _____ kPa

Table 28 — Measurement no. 4 (5 runs)

Test load (unit) (g, kg, t)	Run no. 1		Run no. 2		Run no. 3		Run no. 4		Run no. 5		Average indication ()
	indication ()	Time	indication ()	Time	indication ()	Time	indication ()	Time	indication ()	Time	
										span	

Evaluator: _____ Remarks:

Date: _____

Time: _____

Temperature: _____ °C

Relative humidity: _____ %

Barometric pressure: _____ kPa

Table 29 — Measurement no. 5 (5 runs)

Test load (unit) (g, kg, t)	Run no. 1		Run no. 2		Run no. 3		Run no. 4		Run no. 5		Average indication ()
	indication ()	Time	indication ()	Time	indication ()	Time	indication ()	Time	indication ()	Time	
										span	

Evaluator: _____ Remarks:

Date: _____

Time: _____

Temperature: _____ °C

Relative humidity: _____ %

Barometric pressure: _____ kPa

Table 30 — Measurement no. 6 (5 runs)

Test load (unit) (g, kg, t)	Run no. 1		Run no. 2		Run no. 3		Run no. 4		Run no. 5		Average indication ()
	indication ()	Time	indication ()	Time	indication ()	Time	indication ()	Time	indication ()	Time	

Table 30 (continued)

Test load (unit) (g, kg, t)	Run no. 1		Run no. 2		Run no. 3		Run no. 4		Run no. 5		Average indication ()
	indication ()	Time	indication ()	Time	indication ()	Time	indication ()	Time	indication ()	Time	
										span	

Evaluator: _____ Remarks:

Date: _____

Time: _____

Temperature: _____ °C

Relative humidity: _____ %

Barometric pressure: _____ kPa

Table 31 — Measurement no. 7 (5 runs)

Test load (unit) (g, kg, t)	Run no. 1		Run no. 2		Run no. 3		Run no. 4		Run no. 5		Average indication ()
	indication ()	Time	indication ()	Time	indication ()	Time	indication ()	Time	indication ()	Time	
										span	

Evaluator: _____ Remarks:

Date: _____

Time: _____

Temperature: _____ °C

Relative humidity: _____ %

Barometric pressure: _____ kPa

Table 32 — Measurement no. 8 (5 runs)

Test load (unit) (g, kg, t)	Run no. 1		Run no. 2		Run no. 3		Run no. 4		Run no. 5		Average indication ()
	indication ()	Time	indication ()	Time	indication ()	Time	indication ()	Time	indication ()	Time	
										span	

Evaluator: _____ Remarks:

Date: _____

Time: _____

Temperature: _____ °C

Relative humidity: _____ %

Barometric pressure: _____ kPa

6.19.3 Form 6.19.3 Span stability — summary of test results

R 60-1, 5.7.2.6

R 60-2, 2.10.7.11

R 60-3, 2.2.9

Application no.: _____

Load cell model: _____

Serial no.: _____

E_{\max} : _____

n_{LC} : _____

v_{\min} : _____

p_{LC} : _____ DR: _____

Force-generating system: _____

Indicating instrument: _____

Evaluator: _____

Table 33 — Table 6.19.3

Measurement no.	Span		Variation (v_{\min})	Maximum allowable variation (v_{\min})
	()	(v_{\min})		
1				
2				
3				
4				
5				
6				
7				

Table 33 (continued)

Measurement no.	Span		Variation (v_{\min})	Maximum allowable variation (v_{\min})
	()	(v_{\min})		
8				

PASS: # FAIL: #

Remarks:

Metrological regulation for load cells

Part 4: Annexes

Réglementation métrologique des cellules de pesée

Annexes



Contents

Foreword	170
Annex A Definitions from other applicable international publications.....	171
Annex B OIML certificate for load cells — Content of the certificate.....	174
Annex C OIML certificate for load cells.....	176
Annex D Selection of load cell(s) for testing — a practical example.....	180
Annex E Load transmission to the load cell.....	185
Annex F Bibliography.....	189

Foreword

The International Organisation of Legal Metrology (OIML) is a worldwide, intergovernmental organisation whose primary aim is to harmonise the regulations and metrological controls applied by the national metrological services, or related organisations, of its Member States. The main categories of OIML publications are:

- **International Recommendations (OIML R)**, which are model regulations that establish the metrological characteristics required of certain measuring instruments and which specify methods and equipment for checking their conformity. OIML Member States shall implement these Recommendations to the greatest possible extent;
- **International Documents (OIML D)**, which are informative in nature and which are intended to harmonise and improve work in the field of legal metrology;
- **International Guides (OIML G)**, which are also informative in nature and which are intended to give guidelines for the application of certain requirements to legal metrology;
- **International Basic Publications (OIML B)**, which define the operating rules of the various OIML structures and systems; and

OIML Draft Recommendations, Documents and Guides are developed by Project Groups linked to Technical Committees or Subcommittees which comprise representatives from OIML Member States. Certain international and regional institutions also participate on a consultation basis. Cooperative agreements have been established between the OIML and certain institutions, such as ISO and the IEC, with the objective of avoiding contradictory requirements. Consequently, manufacturers and users of measuring instruments, test laboratories, etc. may simultaneously apply OIML publications and those of other institutions.

International Recommendations, Documents, Guides and Basic Publications are published in English (E) and translated into French (F) and are subject to periodic revision.

Additionally, the OIML publishes or participates in the publication of **Vocabularies (OIML V)** and periodically commissions legal metrology experts to write **Expert Reports (OIML E)**. Expert Reports are intended to provide information and advice, and are written solely from the viewpoint of their author, without the involvement of a Technical Committee or Subcommittee, nor that of the CIML. Thus, they do not necessarily represent the views of the OIML.

This publication — Annexes to OIML R 60:2021 — is an updated edition (developed by the OIML Certification System Management Committee) of the Annexes to R 60:2017 (developed by Project Group 1 of OIML Technical Committee TC 9 *Instruments for measuring mass and density*). This updated edition consolidates the Amendment (2019-12-23) to R 60:2017, and includes other editorial and minor technical changes. It was approved for final publication by the International Committee of Legal Metrology at its 56th meeting in October 2021 and was sanctioned by the 16th International Conference on Legal Metrology in 2021. It supersedes the previous edition of R 60 dated 2017.

OIML Publications may be downloaded from the OIML web site in the form of PDF files. Additional information on OIML Publications may be obtained from the Organisation's headquarters:

Bureau International de Métrologie Légale
11, rue Turgot — 75009 Paris — France
Telephone: 33 (0)1 48 78 12 82
Fax: 33 (0)1 42 82 17 27
E-mail: biml@oiml.org
Internet: www.oiml.org

Annex A

(normative)

Definitions from other applicable international publications

A.1 Terms and definitions

A.1.1

electronic measuring instrument (OIML D 11, 3.1)

instrument intended to measure an electrical or non-electrical quantity using electronic means and/or equipped with electronic devices

A.1.2

module (OIML D11, 3.2)

device performing a specific function or functions and (usually) manufactured and constructed such that it can be separately evaluated according to prescribed metrological and technical performance requirements

A.1.3

device (OIML D 11, 3.3)

identifiable instrument or part of an instrument or of a family of instruments that performs a specific function or functions

A.1.4

checking facility (OIML D11, 3.19)

facility incorporated in a measuring instrument which enables significant faults to be detected and acted upon

A.1.5

automatic checking facility (OIML D 11, 3.19.1)

checking facility that operates without the intervention of an operator

A.1.6

permanent automatic checking facility (type P) (OIML D 11, 3.19.1.1)

automatic checking facility that operates at each measurement cycle

A.1.7

intermittent automatic checking facility (type I) (OIML D 11, 3.19.1.2)

automatic checking facility that operates at certain time intervals or per fixed number of measurement cycles

A.1.8

non-automatic checking facility (type N) (OIML D 11, 3.19.2)

checking facility that requires the intervention of an operator

**A.1.9
durability protection facility (OIML D 11, 3.20)**

facility incorporated in a measuring instrument that enables significant durability errors to be detected and acted upon

**A.1.10
test (OIML D 11, 3.21)**

series of operations intended to verify the compliance of the equipment under test (EUT) with specified requirements

**A.1.11
test procedure (OIML D 11, 3.21.1)**

detailed description of the test operations

**A.1.12
performance test (OIML D 11, 3.21.4)**

test intended to verify whether the EUT is able to accomplish its intended functions

**A.1.13
mains power (OIML D 11, 3.22)**

primary external source of electrical power for an instrument, including all sub-assemblies. (Examples: public or local power grid (AC or DC) or external generator)

**A.1.14
power converter (power supply device) (OIML D 11, 3.23)**

sub-assembly converting the voltage from the mains power to a voltage suitable for other sub-assemblies

**A.1.15
auxiliary battery (OIML D 11, 3.25)**

battery that is

- mounted in, or connected to, an instrument that can be powered by the mains power as well, and
- capable of supplying power to the complete instrument for a reasonable period of time

**A.1.16
back-up battery (OIML D 11, 3.26)**

battery that is intended to maintain power supply for specific functions of an instrument in the absence of the primary power supply that includes both mains power & auxiliary battery

EXAMPLE To preserve stored data

A.2 Definitions from OIML R 76 [1]

**A.2.1
weighing module (OIML R 76-1, T.2.2.7)**

part of the weighing instrument that comprises all mechanical and electronic devices (i.e. load receptor, load-transmitting device, load cell, and analogue data processing device or digital data processing

device) but not having the means to display the weighing result. It may optionally have devices for further processing (digital) data and operating the instrument

Annex B (normative)

OIML certificate for load cells — Content of the certificate

The OIML certificate template that can be downloaded from the “Documentation” section of the OIML Certification System (OIML-CS) part of the OIML website shall be supplemented with the following additional information:

<i>Model designation</i>				
Maximum capacity, E_{\max}				
Accuracy class				
Maximum number of load cell				
verification intervals, n_{LC}				
Minimum load cell verification				
interval, v_{\min}				
Apportioning factor, p_{LC}				

Additional characteristics and identification, as applicable according to R 60-1, 3.4.2 and 5.1.5, may be included in the certificate or on additional pages if necessary, in the format below:

<i>Model designation</i>				
(Additional characteristics, per R 60-1, 3.4.2 and 5.1.5)				

Special conditions:

B.1 Contents of any additional pages to the certificate (Informative)

Name and type of the load cell:

B.2 Technical data

The essential technical data for OIML certificates are listed on the certificate (at the request of the manufacturer). Alternatively, in the case of limited space on the certificate, the following information may be provided on additional pages to the certificate:

Table B.1 — Technical data

Model designation	Designation	Example		Units
Classification		C4		
Additional markings		-		
Maximum number of load cell verification intervals	n_{LC}	4 000		
Maximum capacity	E_{max}	30 000		kg
Minimum dead load, relative	E_{min}/E_{max}	0		%
Relative v_{min} (ratio to minimum load cell verification interval)	$Y = (E_{max} - E_{min}) / (v_{min})$	24 000		
Relative DR (ratio to minimum dead load output return)	$Z = (E_{max} - E_{min}) / (2 \times DR)$	7 500		
Rated output ^a		2.5		mVV ^{-1a}
Maximum excitation voltage		30		V
Input impedance (for strain gauge load cells)	R_{LC}	4 000		Ω
Temperature rating		— 10/+ 40		°C
Safe overload, relative	E_{lim}/E_{max}	150		%
Cable length		3		m
Additional characteristics per R 60-1, 3.4.2 and 5.1.5 ^b		-		
^a For load cells with digital output this refers to the number of counts for E_{max} . ^b For load cells with digital output this is not required.				

Annex C (informative) OIML certificate for load cells

This Annex is provided as an example of supplemental information that may be included in the OIML certificate and is intended to complement the information found in Annex B.

C.1 Certificate history

Certificate version	Date	Essential changes
Rev. 0	DD MM YYYY	Certificate first issued

C.2 Technical data

The metrological characteristics of the load cells type xxx are listed in Table C.1. Further technical data are listed in the data sheet of the manufacturer (see the section “6 Data sheet and dimensions” in this Annex).

Table C.1 — Essential data

Accuracy class		C
Maximum number of load cell intervals n_{LC}		3 000
Rated output	mVV ⁻¹	2
Maximum capacity E_{max}	kg	150 / 200 / 250 / 300 / 500 / 750
Minimum load cell verification interval $v_{min} = (E_{max} - E_{min}) / Y$	kg	$E_{max} / 15\ 000$
Minimum dead load output return $DR = 1/2 (E_{max} - E_{min}) / Z$	kg	$1/2 (E_{max} - E_{min}) / 5\ 000$

Dead load: xxx % · E_{max} ; Safe overload: xxx % · E_{max} ; Input impedance: xxx Ω

C.3 Tests

The determination of the measurement error, the stability of the dead load output, repeatability and creep in the temperature range of -10 °C to $+40\text{ °C}$ as well as the tests of barometric pressure effects and the determination of the effects of damp heat steady state have been performed according to OIML R 60 as shown in Table C.1 on the load cell denominated in the test report with the reference No. xxx, dated xxx.

Table C.2 — Tests performed

Test	R 60	Tested samples	Result
Temperature test and repeatability at ($20/40/-10/20\text{ °C}$)	R 60-1, 5.3.2; 5.4; R 60-2, 2.10.1	150 kg	+

Table C.2 (continued)

Test	R 60	Tested samples	Result
Temp. effect on minimum dead load output at (20/40/ – 10/20 °C)	R 60-1, 5.6.1.3; R 60-2, 2.10.1.16	150 kg	+
Creep test at (20/40/ – 10/20 °C)	R 60-1, 5.5.1; R 60-2, 2.10.2	150 kg	+
Minimum dead load output return at (20/40/ – 10/20 °C)	R 60-1, 5.5.2; R 60-2, 2.10.3	150 kg	+
Barometric pressure effects at ambient temperature	R 60-1, 5.6.2; R 60-2, 2.10.4	150 kg	+
Damp heat test, static, marked SH	R 60-1, 5.6.3.2; R 60-2, 2.10.6	150 kg	+

C.4 Description of the load cell

EXAMPLE:

The load cells (LC) of the series xxx are double bending beam load cells. They are made of aluminium, and the strain gauge application is hermetically sealed. Further essential characteristics are given in the data sheet (see the section “6 Data sheet and dimensions” in this Annex).

[Include a picture/diagram of the load cell]

Figure 1 — Load cell type xxx

The complete type designation is indicated as follows in the example on the name plate:

[Include a picture/diagram of the name plate]

Figure 2 — Name plate

C.5 Documentation

EXAMPLE:

- Test Report No. xxx; C3; Y = xxx; Z = xxx; E_{\max} = xxx kg; SN: xxx
- Datasheet No. Xxx
- Technical Drawing No. Xxx

C.6 Further information

The manufacturing process, material and sealing (i.e., environmental protection) of the produced load cells shall be in accordance with the tested patterns; essential changes shall be identified and communicated to the issuing authority and are only allowed with the permission of the issuing authority based on the impact of those changes on the certification process.

Sufficient information shall be included to describe the patent design.

The typical errors related to linearity, hysteresis and temperature coefficient as indicated in the data sheet point out possible single errors of a pattern; however, the overall error of each pattern is determined by the maximum permissible error according OIML R 60-1, 5.3.2.

The technical data, the dimensions of the load cell and the principle of load transmission are given in section 6 of this Annex, “Data sheet and dimensions”, and shall be complied with.

C.7 Data sheet and dimensions

Specifications of the load cell family

Accuracy class according to OIML R 60			C
Rated output		mVV ⁻¹	2,0 ± 0,2
Maximum capacity	E_{\max}	kg	150 / 200 / 250 / 300 / 500 / 750
Max. number of load cell intervals	n_{LC}		3 000
Min. load cell verification interval	v_{\min}	kg	$E_{\max} / 15\,000$
Minimum dead load output return (MDLOR)	DR	kg	$1/2 \cdot E_{\max} / 5\,000$
Minimum dead load		$\% \cdot E_{\max}$	0
Safe load limit		$\% \cdot E_{\max}$	150
Ultimate load		$\% \cdot E_{\max}$	300
Excitation voltage, recommended	U_{EXE}	V	10-12 DC
Excitation voltage, maximum		V	15 DC
Input resistance	R_{LC}	Ω	404 ± 10
Output resistance	R_{out}	Ω	350 ± 3
Insulation resistance	RISO	M Ω	≈ 2 000
Compensated temperature range	T	°C	- 10 ... + 40
Load cell material			Aluminium
Cable length	L	m	2
Coating			Silicone rubber

C.8 Wiring

The load cell is provided with a shielded 4- or 6-wire cable. The cable length is indicated in the accompanying document. The shield will be connected or not connected to the load cell according to the customer's preference.

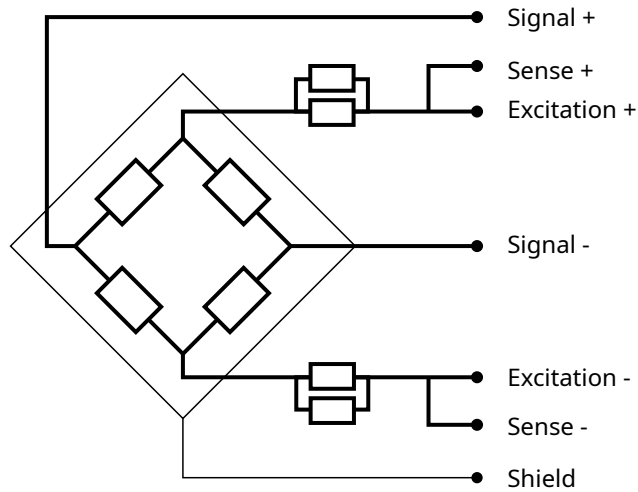

C.9 Connections

Connections	4-wire	6-wire
Excitation +	red	red
Excitation -	black	black
Signal +	green	green
Signal -	white	white
Sense +	-	blue
Sense -	-	yellow
Shield	purple	purple
Cable length	2 m	

C.10 Dimensions

[Include a picture/diagram of the load cell dimensions]

Annex D (informative)

Selection of load cell(s) for testing — a practical example

D.1 This Annex describes a practical example showing the complete procedure for the selection of test samples out of a load cell family.

D.2 Assume a family consisting of three groups of load cells, differing in class, maximum number of load cell verification intervals, n_{LC} , and maximum capacities, E_{max} . The capacities, E_{max} , overlap between the groups according to the following example:

- Group 1 Class C, $n_{LC} = 6\ 000$, $Y = 18\ 000$, $Z = 6\ 000$
 E_{max} : 50 kg, 100 kg, 300 kg and 500 kg
- Group 2 Class C, $n_{LC} = 3\ 000$, $Y = 12\ 000$, $Z = 4\ 000$
 E_{max} : 100 kg, 300 kg, 500 kg, 5 000 kg, 10 t, 30 t and 50 t
- Group 3 Class B, $n_{LC} = 10\ 000$, $Y = 25\ 000$, $Z = 10\ 000$
 E_{max} : 500 kg, 1 000 kg and 4 000 kg

D.2.1 Summarise and sort the load cells with respect to E_{max} and accuracy as follows:

Class	Y	← lowest			E_{max} , kg		→ highest						
		n_{LC}	Group	Z	v_{min} , kg								
C3	12 000				100	300	500			5 000	10 000	30 000	50 000
3 000													
2	4 000				0,008 3	0,025	0,042			0,42	0,83	2,5	4,17
C6	18 000	50			100	300	500						
6 000													
1	6 000	0,002 8	0,005 5	0,016 7	0,028								
B10	25 000						500	1 000	4 000				
10 000													
3	10 000						0,020	0,040	0,16				

D.2.2 Identify the smallest capacity load cells in each group to be tested, according to R 60-2, 2.4:

Class	Y	← lowest			E_{max} , kg		→ highest				
		n_{LC}	Group	Z	v_{min} , kg						

C3	12 000		100	300	500			5 000	10 000	30 000	50 000
3 000											
2	4 000		0,008 3	0,025	0,042			0,42	0,83	2,5	4,17
C6	18 000	50	100	300	500						
6 000											
1	6 000	0,028	0,005 5	0,016 7	0,002 8						
B10	25 000				500	1 000	4 000				
10 000											
3	10 000				0,020	0,040	0,16				

In this example, select and identify:

C6—50 kg (full evaluation test required)

B10—500 kg (full evaluation test required)

Although load cell C3—100 kg is the smallest capacity in its group, its capacity falls within the range of other selected load cells having better metrological characteristics. Therefore, it is not selected.

D.2.3 Begin with the group with the best metrological characteristics (in this example, B10) and in accordance with R 60-2, 2.4.2, select the next largest capacity between 5 and 10 times that of the nearest smaller capacity load cell which has been selected. When no capacity meets this criterion, the selected load cell shall be that having the smallest capacity exceeding 10 times that of the nearest smaller capacity load cell which has been selected. Continue this process until all load cell capacities in the group have been considered.

Class	Y	<--- lowest				E_{max} , kg	---> highest				
n_{LC}											
Group	Z					v_{min} , kg					
C3	12 000		100	300	500			5 000	10 000	30 000	50 000
3 000											
2	4 000		0,008 3	0,025	0,042			0,42	0,83	2,5	4,17
C6	18 000	50	100	300	500						
6 000											
1	6 000	0,002 8	0,005 5	0,016 7	0,028						
B10	25 000				500	1 000	4 000				
10 000											
3	10 000				0,020	0,040	0,16				

In this example, select and identify:

B10—4 000 kg (full evaluation test required)

D.2.4 Move to the group with the next best characteristics (in this example, C6) and, in accordance with R 60-2, 2.4.2 select the next largest capacity between 5 and 10 times that of the nearest smaller capacity load cell which has been selected. When no capacity meets this criterion, the selected load cell shall be that having the smallest capacity exceeding 10 times that of the nearest smaller capacity load cell which has been selected. Continue this process until all load cell capacities in the group have been considered.

Class n_{LC} Group	Y	← lowest			E_{max} , kg		→ highest				
		Z				v_{min} , kg					
C3 3 000 2	12 000 4 000		100 0,008 3	300 0,025	500 0,042			5 000 0,42	10 000 0,83	30 000 2,5	50 000 4,17
C6 6 000 1	18 000 6 000	50 0,002 8	100 0,005 5	300 0,016 7	500 0,028						
B10 10 000 3	25 000 10 000				500 0,020	1 000 0,040	4 000 0,16				

In this example, **there is no change** to the load cells selected. The capacities of the load cells C6—300 kg and C6—500 kg exceed the capacity of the load cell C6—50 kg by greater than 5 times but not greater than 10 times. However, a 500 kg load cell of better metrological characteristics (from group B10) has already been selected. Therefore, in order to minimise the number of load cells to be tested according to R 60-2, 2.3.1, neither cell is selected.

D.2.5 Again, and repeating this process until all groups have been considered, move to the group with the next best characteristics (in this example, C3) and in accordance with R 60-2, 2.4.4, select the next largest capacity between 5 and 10 times that of the nearest smaller capacity load cell which has been selected. When no capacity meets this criterion, the selected load cell shall be that having the smallest capacity exceeding 10 times that of the nearest smaller capacity load cell which has been selected. Continue this process until all load cell capacities in the group and all groups have been considered.

Class n_{LC} Group	Y	← lowest			E_{max} , kg		→ highest				
		Z				v_{min} , kg					
C3 3 000 2	12 000 4 000		100 0,008 3	300 0,025	500 0,042			5 000 0,42	10 000 0,83	30 000 2,5	50 000 4,17
C6 6 000 1	18 000 6 000	50 0,002 8	100 0,005 5	300 0,016 7	500 0,028						

B10	25 000				500	1 000	4 000				
10 000											
3	10 000				0,020	0,040	0,16				

In this example, select and identify:

C3 — 30 000 kg (full evaluation test required) Proceeding from smallest to largest capacity, the only capacity of load cell which is greater than 5 times the capacity of an already selected load cell but less than 10 times that capacity is the C3 — 30 000 kg load cell. Since the capacity of the C3 — 50 000 kg load cell does not exceed 5 times the capacity of the next smaller selected load cell, which is C3 — 30 000 kg, according to R 60-2, 2.4.3 it is presumed to comply the requirements of this Recommendation.

D.2.6 After completing steps D.2.2 to D.2.5 and identifying the load cells, compare load cells of the same capacity from different groups. Identify the load cells with the highest accuracy class and highest n_{LC} in each group (see shaded portion of table below). For those load cells of the same capacity but from different groups, identify only the one with the highest accuracy class and n_{LC} and lowest v_{min} .

Class	Y	← lowest			E_{max} , kg		→ highest				
		n_{LC}	Z	Group	v_{min} , kg						
C3	12 000										
3 000											
2	4 000		0,008 3	0,025	0,042			0,42	0,83	2,5	4,17
C6	18 000	50	100	300	500						
6 000											
1	6 000	0,002 8	0,005 5	0,016 7	0,028						
B10	25 000				500	1 000	4 000				
10 000											
3	10 000				0,020	0,040	0,16				

Inspect the values of v_{min} , Y, and Z for all cells of the same capacity.

If any load cell of the same capacity has a lower v_{min} or higher Y than the identified load cell, that load cell (or load cells) is also liable for partial evaluation testing, specifically the conduct of additional temperature effect on minimum dead load, E_{min} and barometric pressure effect tests.

If any load cell of the same capacity has a higher Y than the selected load cell, that load cell (or load cells) is also liable for partial evaluation testing, specifically the conduct of additional creep and DR tests.

In this example, the **load cells identified above also have the best characteristics of lowest v_{min} , highest Y and highest Z**. This is normally the case, but not always.

D.2.7 If applicable, select the load cell for humidity testing in accordance with R 60-2, 2.4.5, that being the load cell with the most severe characteristics, for example the greatest value of n_{LC} or the lowest value of v_{min} .

In this example, the load cell with the greatest value of n_{LC} or the lowest value of v_{min} is the same load cell, therefore select:

B10 — 500 kg (humidity test required)

NOTE: The other B10 load cells also possess the same qualifications and are possible choices. The 500 kg load cell was chosen because it is the smallest of the applicable B10 capacities. Although the C6 — 50 kg load cell has the lowest v_{min} of 0,002 8, the B10 load cells have the highest n_{LC} , highest accuracy class, and the highest Y and Z .

D.2.8 If applicable, select the load cell for the additional tests to be performed on digital load cells in accordance with R 60-2, 2.4.6, that being the load cell with the most severe characteristics, for example the greatest value of n_{max} or the lowest value of v_{min} .

2+h| **D.2.9** Summarising, the load cells selected for test are:

<i>Summary</i>	<i>Selected cells</i>
Load cells requiring full evaluation test	C6 — 50 kg B10 — 500 kg B10 — 4 000 kg C3 — 30 000 kg
Load cells requiring partial evaluation test	None
Load cell to be tested for humidity	B10 — 500 kg
Digital load cells for additional tests	None

In this example, no load cell in the family is equipped with electronics.

Annex E (informative)

Load transmission to the load cell

This Annex is taken from the WELMEC 2.4 (European cooperation in legal metrology) Guide for Load Cells (Issue 2, published in August, 2001). With permission from WELMEC, the following portion of that Guide is reprinted here to provide guidelines for load cell evaluators, during load cell performance evaluations. Recognising the critical role that load cell receptors and load transmission devices play in accurate measurements, this Annex is intended to provide information regarding the effect of load transmission and recommendations for test design and procedure. The annex is informational and not to be considered required practice.

For some types of load cells, the kind of load transmission to the load cell has an influence on the measurements and therefore on the test results.





In this Annex the standard load transmission devices are listed.

The manufacturer should define whether the load cell works with all standard load transmission devices for the type of load cell or with selected standard load transmission devices or with a load cell specific load transmission devices.

This information may be considered for the load cell tests and may be marked on the certificate.

Standard load transmission devices

Tables E.1 and E.2 identify different types of LCs, (compression, tension, ...) and typical load cell mounting devices suitable for them. The symbols below classify the mobility between one point of contact on the load cell and its counterpart on the load receptor or mounting base.

Symbol	Description
 Figure E.1	Movement possible normal to load axis <i>NOTE</i> allows for temperature dilatation <i>1:</i>
 Figure E.2	Movement possible normal to load axis, with reversing force (spring-back effect) <i>NOTE</i> allows for temperature dilatation, also used for damping of lateral shock <i>2:</i>
 Figure E.3	Inclination possible <i>NOTE</i> allows for tilt of load cell or deflection of load receptor, no movement <i>3:</i> normal to load axis possible
 Figure E.4	Indicates auto-centring effect of the complete mounting assembly of one load cell

Remarks on the standard load transmission devices presented in Tables E.1 and E.2 :

All combinations of load cell and transmitting device shown in Tables E.1 and E.2 can also be utilised in a completely reversed manner.

The load transmission device is independent of the encapsulation, potting or housing which are shown in the examples.

a) Compression LCs (Table E.1, upper part)

- The load transmissions 1 to 8 are presented for canister type LCs. Instead, all load transmissions may be constructed for S-type or ring type load cells.
- 6a shows a pendulum construction build as a complete unit.
- 6b and 6c show external pendulum rocker pins combined with ring-type LCs.
- The bearings for all compression load cells may be installed either below or above the LC.

b) Tension LCs (Table E.1, lower part)

- The load transmissions 1 and 2 are presented for canister type LCs. Alternatively, both load transmissions may be used for S-type LCs.

c) Beam LCs (Table E.2, upper part)

- The drawings present double bending and shear beams, as well as plastic potted and encapsulated constructions; all these constructions may be combined with either of the load transmissions 1 to 10.
- The direction of loading, which is given by the manufacturer, has to be observed.

d) Single point LCs (Table E.2, middle part)

- The load transmissions 1 to 10 for the beam LCs may be applied to all single point LCs.
- The direction of loading, which is given by the manufacturer, has to be observed.

e) Double bending beam LCs (Table E.2, lower part)

- The table shows examples of common constructions. Variations are possible provided the constructions allow enough horizontal flexibility between both ends.
- The direction of loading, provided by the manufacturer, has to be observed.

The single bending beams had been exempted for general acceptance, because very small displacements of the “force transducing point” may lead to a change of span and linearity.

Table E.1 — Schematic drawings for compression and tension LCs

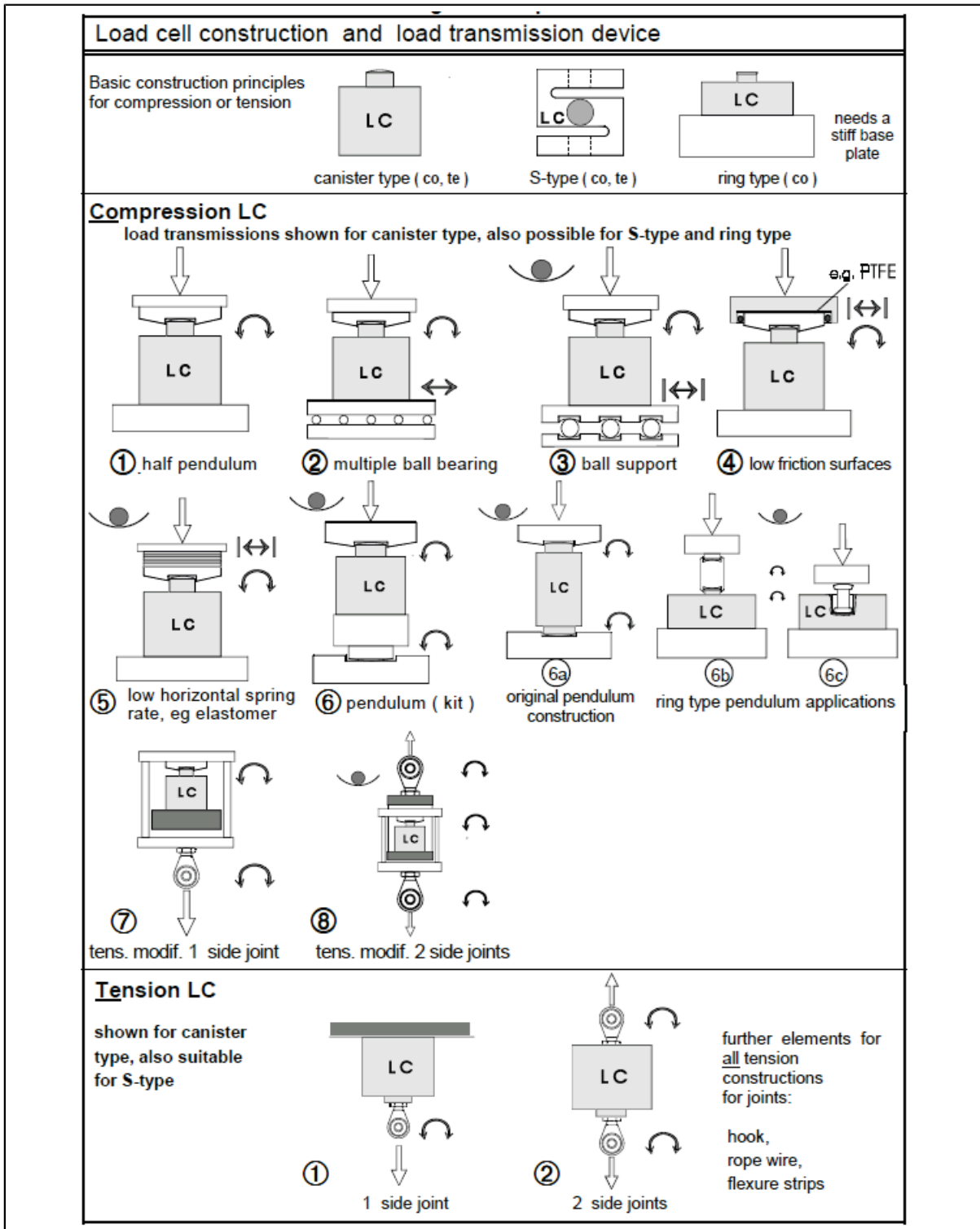

Table E.2 — Schematic drawings for beam LCs

Load cell construction and load transmission device The load transmission device is independent of the encapsulation, potting or housing and the mounting at the fixed end shown below	
Beam LC - Cantilever beam Double bending beam & Shear beam LC	
Single point LC	<p>The single point LC has no degree of freedom for horizontal displacement or inclination, using more than one LC in a load receptor decoupling elements are necessary. The load transmissions 1 to 10 for the beam LCs may be applied. Max. platform dimensions may be mentioned in the TC or the TAC.</p>
Double ended beam LC	
Constructions with fixed clamping at the two ends need for minimum displacement and inclination some elasticity of the supporting construction.	

Annex F

(informative)

Bibliography

- [1] ISO 8601:2004¹⁾, *Data elements and interchange formats — Information interchange — Representation of dates and times*
- [2] IEC 60068-2-78:2012, *Environmental testing — Part 2-78: Tests — Test Cab: Damp heat, steady state*
- [3] IEC 60068-3-4:2001, *Environmental testing — Part 3-4: Supporting documentation and guidance — Damp heat tests*
- [4] IEC 61000-4-11:2020, *Electromagnetic compatibility (EMC) — Part 4-11: Testing and measurement techniques — Voltage dips, short interruptions and voltage variations immunity tests for equipment with input current up to 16 A per phase*
- [5] IEC 61000-4-1:2006, *Electromagnetic compatibility (EMC) — Part 4-1: Testing and measurement techniques — Overview of IEC 61000-4 series*
- [6] IEC 61000-4-29:2000, *Electromagnetic compatibility (EMC) — Part 4-29: Testing and measurement techniques — Voltage dips, short interruptions and voltage variations on d.c. input power port immunity tests*
- [7] IEC 61000-4-2:2008, *Electromagnetic compatibility (EMC) — Part 4-2: Testing and measurement techniques — Electrostatic discharge immunity test*
- [8] IEC 61000-4-3:2020, *Electromagnetic compatibility (EMC) — Part 4-3 : Testing and measurement techniques — Radiated, radio-frequency, electromagnetic field immunity test*
- [9] IEC 61000-4-4:2012, *Electromagnetic compatibility (EMC) — Part 4-4: Testing and measurement techniques — Electrical fast transient/burst immunity test*
- [10] IEC 61000-4-5:2014, *Electromagnetic compatibility (EMC) — Part 4-5: Testing and measurement techniques — Surge immunity test*
- [11] IEC 61000-4-6:2013, *Electromagnetic compatibility (EMC) — Part 4-6: Testing and measurement techniques — Immunity to conducted disturbances, induced by radio-frequency fields*
- [12] IEC 61000-6-1:2016, *Electromagnetic compatibility (EMC) — Part 6-1: Generic standards — Immunity standard for residential, commercial and light-industrial environments*
- [13] IEC 61000-6-2:2016, *Electromagnetic compatibility (EMC) — Part 6-2: Generic standards — Immunity standard for industrial environments*

1) Cancelled and replaced by ISO 8601-1:2019.

- [14] IEC 60068-2-30:2005, *IEC Publication 60068-2-30:2005 Environmental testing — Part 2-30: Tests — Test Db: Damp heat, cyclic (12 h + 12 h cycle)*
- [15] IEC 61000-2-1:1990, *IEC Publication 61000-2-1:1990 Electromagnetic compatibility (EMC) — Part 2: Environment — Section 1: Description of the environment — Electromagnetic environment for low-frequency conducted disturbances and signalling in public power supply systems*
- [16] OIML-CS, Procedural Document PD-05 (Edition 2) *Processing an OIML Type Evaluation Report and OIML Certificate*
- [17] OIML G 1-100:2008, *Guide to the Expression of Uncertainty in Measurement, BIPM, IEC, IFCC, ISO, IUPAC, IUPAP, OIML*
- [18] OIML V 2:2013, *International Vocabulary of Terms in Legal Metrology (VIML)*
- [19] OIML V 2-200:2012, *International Vocabulary of Metrology — Basic and General Concepts and Associated Terms (VIM)*
- [20] OIML D 9:2004, *Principles of metrological supervision*
- [21] OIML D 11:2008, *General requirements for electronic measuring instruments*
- [22] OIML B 18:2018, *Framework for the OIML Certification System (OIML-CS)*
- [23] OIML D 31:2008, *General requirements for software controlled measuring instruments*
- [24] OIML R 50:2014, *OIML R 50:2014 Continuous totalizing automatic weighing instruments (belt weighers)*
- [25] OIML R 51:2006, *Automatic catchweighing instruments*
- [26] OIML R 61:2017, *Automatic gravimetric filling instruments*
- [27] OIML R 76:2006, *Non-automatic weighing instruments*
- [28] OIML R 106, *Automatic rail-weighbridges*