

WORKING
DRAFT

INTERNATIONAL
STANDARD **17301-1:2016/**
AWI Amd
1:2017

AMENDMENT 1

ISO/TC 34/SC 4/WG 4

**Cereals and pulses — Specification
and test methods —**

Part 1:
Rice (WD)

**AMENDMENT 1: Mass fraction
of extraneous matter, milled rice
(nonglutinous), sample dividers and
recommendations relating to storage and
transport conditions**

*Céréales et légumineuses — Spécification et méthodes d'essai —
Partie 1: Riz (WD)*

*AMENDEMENT 1: Fraction massique de matière étrangère, riz usiné
(non gluant), diviseurs d'échantillon et recommandations relatives aux
conditions d'entreposage et de transport*

ICS: 67.060

THIS DOCUMENT IS A DRAFT CIRCULATED FOR COMMENT AND APPROVAL. IT IS THEREFORE SUBJECT TO CHANGE AND MAY NOT BE REFERRED TO AS AN INTERNATIONAL STANDARD UNTIL PUBLISHED AS SUCH.

RECIPIENTS OF THIS DRAFT ARE INVITED TO SUBMIT, WITH THEIR COMMENTS, NOTIFICATION OF ANY RELEVANT PATENT RIGHTS OF WHICH THEY ARE AWARE AND TO PROVIDE SUPPORTING DOCUMENTATION.

IN ADDITION TO THEIR EVALUATION AS BEING ACCEPTABLE FOR INDUSTRIAL, TECHNOLOGICAL, COMMERCIAL AND USER PURPOSES, DRAFT INTERNATIONAL STANDARDS MAY ON OCCASION HAVE TO BE CONSIDERED IN THE LIGHT OF THEIR POTENTIAL TO BECOME STANDARDS TO WHICH REFERENCE MAY BE MADE IN NATIONAL REGULATIONS.



Reference number
ISO 17301-1:2016/AWI Amd
1:2017(E)

© ISO 2017

© ISO 2017

All rights reserved. Unless otherwise specified, or required in the context of its implementation, no part of this publication may be reproduced or utilized otherwise in any form or by any means, electronic or mechanical, including photocopying, or posting on the internet or an intranet, without prior written permission. Permission can be requested from either ISO at the address below or ISO's member body in the country of the requester.

ISO copyright office
CP 401 • Ch. de Blandonnet 8
CH-1214 Vernier, Geneva
Phone: +41 22 749 01 11
Email: copyright@iso.org
Website: www.iso.org

Published in Switzerland

Foreword

ISO (the International Organization for Standardization) is a worldwide federation of national standards bodies (ISO member bodies). The work of preparing International Standards is normally carried out through ISO technical committees. Each member body interested in a subject for which a technical committee has been established has the right to be represented on that committee. International organizations, governmental and non-governmental, in liaison with ISO, also take part in the work. ISO collaborates closely with the International Electrotechnical Commission (IEC) on all matters of electrotechnical standardization.

The procedures used to develop this document and those intended for its further maintenance are described in the ISO/IEC Directives, Part 1. In particular the different approval criteria needed for the different types of ISO documents should be noted. This document was drafted in accordance with the editorial rules of the ISO/IEC Directives, Part 2 (see www.iso.org/directives).

Attention is drawn to the possibility that some of the elements of this document may be the subject of patent rights. ISO shall not be held responsible for identifying any or all such patent rights. Details of any patent rights identified during the development of the document will be in the Introduction and/or on the ISO list of patent declarations received (see www.iso.org/patents).

Any trade name used in this document is information given for the convenience of users and does not constitute an endorsement.

For an explanation on the voluntary nature of standards, the meaning of ISO specific terms and expressions related to conformity assessment, as well as information about ISO's adherence to the World Trade Organization (WTO) principles in the Technical Barriers to Trade (TBT) see the following URL: www.iso.org/iso/foreword.html.

This document was prepared by Technical Committee ISO/{technical-committee-type} 34, *Food products*, Subcommittee SC 4, *Cereals and pulses*.

A list of all parts in the ISO 17301 series can be found on the ISO website.

Cereals and pulses — Specification and test methods —

Part 1:

Rice (WD)

AMENDMENT 1: Mass fraction of extraneous matter, milled rice (nonglutinous), sample dividers and recommendations relating to storage and transport conditions



Introduction

Delete the fourth to seventh paragraphs.

Normative references

Replace the reference to ISO 16634:— (including the footnote) with the following:

ISO 16634-2:2016, *Food products — Determination of the total nitrogen content by combustion according to the Dumas principle and calculation of the crude protein content — Part 2: Cereals, pulses and milled cereal products*

Renumber subsequent footnotes.

4.1, second paragraph

Replace the paragraph with the following:

There shall be a procedure to identify the maximum permissible levels for additives and pesticide residues and other contaminants in the country of destination.

4.2.1

Designate the existing NOTE as NOTE 1 and add the following new NOTE:

NOTE 2 For certain destinations, no differentiation is made between the organic and inorganic mass fractions of extraneous matter.

4.2.2, Table 1

In the column “in milled rice (non-glutinous)”, replace the value “0,3” for “Paddy” with the value “0,5”.

6.3, first paragraph

Replace the reference “ISO 16634:—, Clause 9” with “ISO 16634-2:2016, Clause 9”.

Clause 8

Add the following paragraph at the end of the clause:

Annex E gives recommendations relating to storage and transport conditions.

Clause 9

Replace the text with the following:

The marking on the packages shall clearly identify the type of rice.

A.2.1

Replace the text with the following:

A.2.1 Sample divider, consisting of a conical sample divider or multiple-slot sample divider with a distribution system, e.g. conical (Boerner-type) divider such as that shown in Figure A.1 or multiple-slot (riffle-type) divider such as that shown in Figure A.2.

Figure A.1

Replace Figure A.1 with the following two figures:

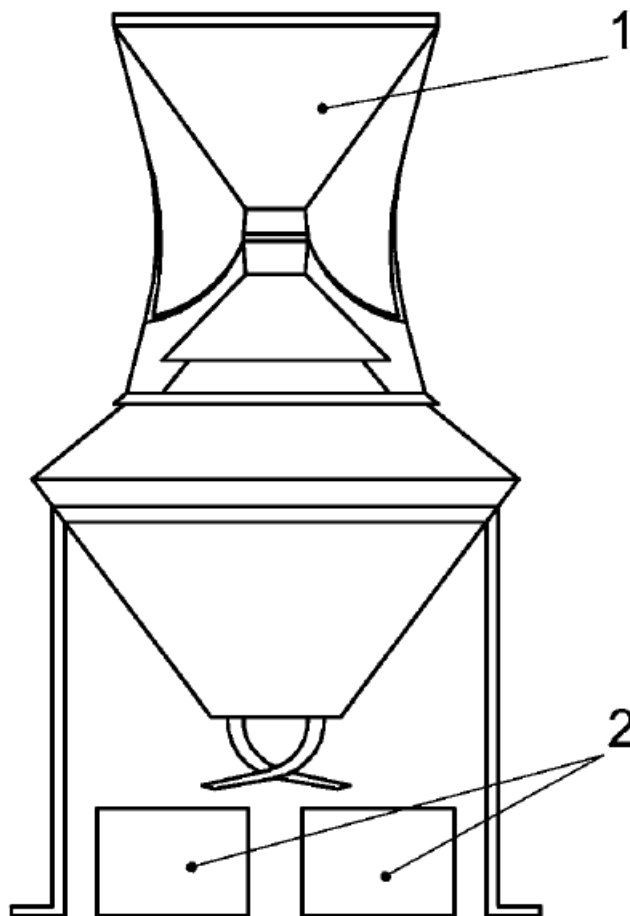

Key

- 1 funnel
- 2 collection boxes

Figure A.1 — Conical (Boerner-type) divider

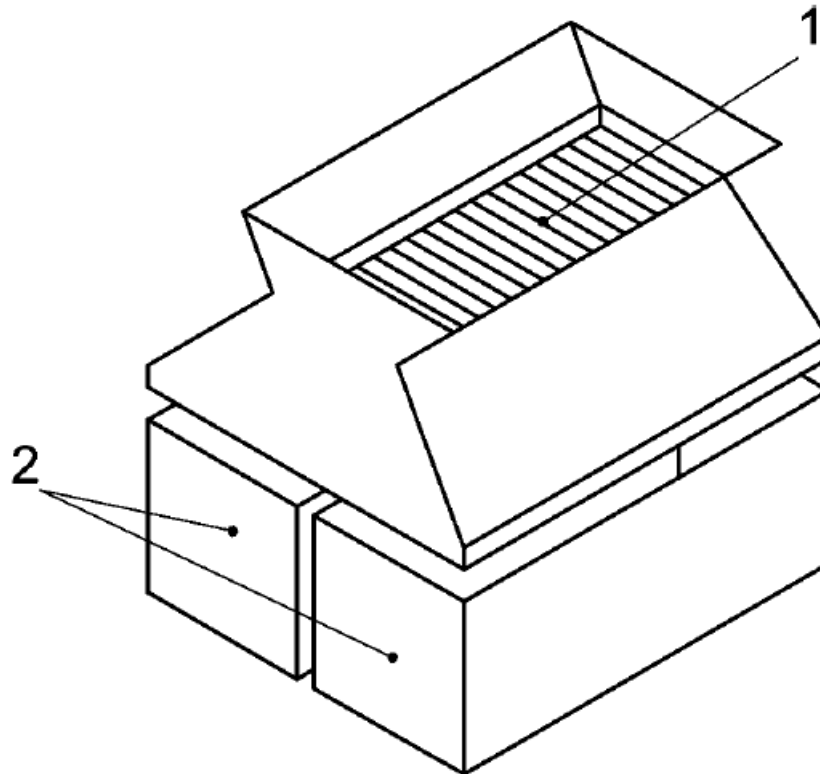

Key

- 1 slots
- 2 collection boxes

Figure A.2 — Multiple-slot (riffle-type) divider with two collection boxes

Annex E

Add the following annex after Annex D, before the Bibliography.

Annex E. Recommendations relating to storage and storage and transport conditions

Containers of rice should be stored in covered premises, well protected from the sun, rain and excessive heat.

The storeroom should be dry, free from unpleasant odours and protected against entry of insects and other vermin. Ventilation should be adjusted in such a way as to give good

ventilation during dry weather and to be fully closed under damp conditions. Suitable provisions should be made for fumigation of storerooms.

Containers should be handled and transported in such a way that they are protected from the rain, sun or other sources of excessive heat, unpleasant odours and any other contamination (especially in the holds of ships).

